

TABLE OF CONTENTS

	Page
1. INTRODUCTION	2
2. SAFETY INSTRUCTION	3
3. TRANSMITTER ILLUSTRATION	
3.1 Alpha 3000F Models External Assembly	4
3.2 Alpha 3000F Models Internal Assembly	5
3.3 Alpha 3000D Models External Assembly	6
3.4 Alpha 3000D Models Internal Assembly	7
4. RECEIVER ILLUSTRATION	
4.1 External Assembly (All Models)	8
4.2 Alpha 3000F Models Internal Assembly	9
4.3 Alpha 3000D Models Internal Assembly	10
5. OUTPUT CONTACT DIAGRAM	
5.1 Alpha 3000F2 Output Contact	11
5.2 Alpha 3000F3 Output Contact	12
5.3 Alpha 3000D2 Output Contact	13
5.4 Alpha 3000D3 Output Contact	14
6. SYSTEM CONFIGURATIONS	
6.1 Jumper Settings	15~17
6.2 Security ID Code Settings	18~19
6.3 Frequency (RF) Channel Settings	19
6.4 Frequency (RF) Channel Table	20
6.5 Pushbutton Contact Settings	21
6.6 Voltage Settings	22
7. RECEIVER INSTALLATION	
7.1 Preparation For Installation	23
7.2 Step-By-Step Installation	23
7.3 System Testing	24
8. TRANSMITTER OPERATION	25~26
9. TROUBLE SHOOTING	27
10. SYSTEM SPECIFICATION	28
11. PARTS LIST	29

1. INTRODUCTION

The Alpha 3000 series are highly durable, reliable, and safe industrial radio remote control system. The versatile features of the Alpha 3000 series permit their usage in many different radio remote control applications that required 2-step or 3-step pushbutton controls. The system can be used to control tower cranes, factory cranes, monorail systems, multiple hoists, trolleys, mining equipment, building construction equipment, automatic control systems, and many others.

The Alpha 3000 radio remote control systems incorporate numerous redundant safety circuits that guaranty maximum security and ensure the system is resistant to outside interference. The major features of the Alpha 3000 series are as follow:

- * The system uses advanced 16+1bit microprocessor control with highly evolved software that has redundant error checking and correcting capabilities to ensure 100% error-free transmission, decoding, and control of all output relays. This highly evolved software includes CRC (cyclical redundancy check codes) and Hamming Codes (error recovery) programming.
- * To insure maximum operating safety, the Alpha 3000 system incorporates numerous important safety features. Some of these built-in safety features include transmitter pushbutton self-diagnosing during initial startup, transmitter low-voltage detection and warning, receiver self-diagnosing, and MAIN deactivation when the transmitter is not in use (programmable).
- * The transmitter encoder and receiver decoder both utilize advanced microprocessor control. The availability of 65,536 sets of unique ID codes + 30 distinct RF channels will ensure that only commands from the matching control transmitter can be carried out without any interference from other radio systems.
- * For added safety, the system also incorporates special type of safety MAIN relay. If the safety MAIN relay becomes defective (fails to open or close during operation), it will signal the central system to shut down immediately to avoid the possibility of any accidents occurring.
- * 30 sets of user-adjustable receiving RF channels via simple dip-switch settings.
- * 100% waterproofed transmitter and receiver enclosures (IP66 rated), including the battery compartment.

Each Alpha 3000 series radio remote control system consists of a water-resistant IP66 handheld transmitter and receiver. The transmitter casing is molded using industrial strength composite materials (Nylon + Fiberglass) which are impervious to dust, water, oil, acids, alkaline, heat, sunlight and as well as being resistant to deformation due to long term use in harsh environments. The industry's best 2-step & 3-step pushbuttons are also constructed from industrial strength composite materials with a minimum of up to one million press cycles. For power savings, the transmitter is designed with an ultra high efficiency power saving circuit that requires only four "AA" size alkaline batteries for more than 200 hours of continuous operation between battery replacements.

2. SAFETY INSTRUCTION

The Alpha 3000 system is relatively simple to use, however, it is very important to observe the proper safety procedures before, during, and after operation. When used properly our Alpha 3000 series remote controls will enhance safety, productivity and efficiency in the workplace.

The following procedures should be strictly followed:

1. Check the transmitter casing and pushbuttons daily. Should any damage that could inhibit the proper operation of the transmitter be found the unit should be immediately removed from service.
2. The transmitter voltage should be checked on a daily basis. If the voltage is low (red status light blinking - refer to page 25), the four "AA" alkaline batteries should be replaced.
3. The red emergency stop button (EMS) should be checked at the beginning of each shift to ensure it is in proper working order and the Stop command is being received.
4. In the event of an emergency, push down the emergency stop button (EMS) immediately to deactivate the receiver MAIN relay. Then turned the power "off" from the main power source to the crane or equipment.
5. The transmitter power key should be pulled "off" after each use and should never leave the transmitter in the power "on" position when the unit is unattended.
6. Do not use the same RF channel and ID code as any other system in use at the same facility or within distance of 900 feet.
7. Ensure the shoulder strap is worn at all time during operation to avoid accidental damage to the transmitter.
8. Never operate a crane or equipment with two transmitter units at the same time with the same RF channel and ID code.

Caution!

Improper Storage of your Spare Transmitter is a Safety Hazard! During the initial installation of your remote control system the spare (second) transmitter should be tested to confirm that it is functioning properly and then the batteries must be removed and the transmitter stored in a secured place. Failure to follow this safety procedure can result in the inadvertent operation of your crane or hoist by unauthorized personnel resulting in serious injury or death!

3. TRANSMITTER ILLUSTRATION

3.1 Alpha 3000F Models External Assembly

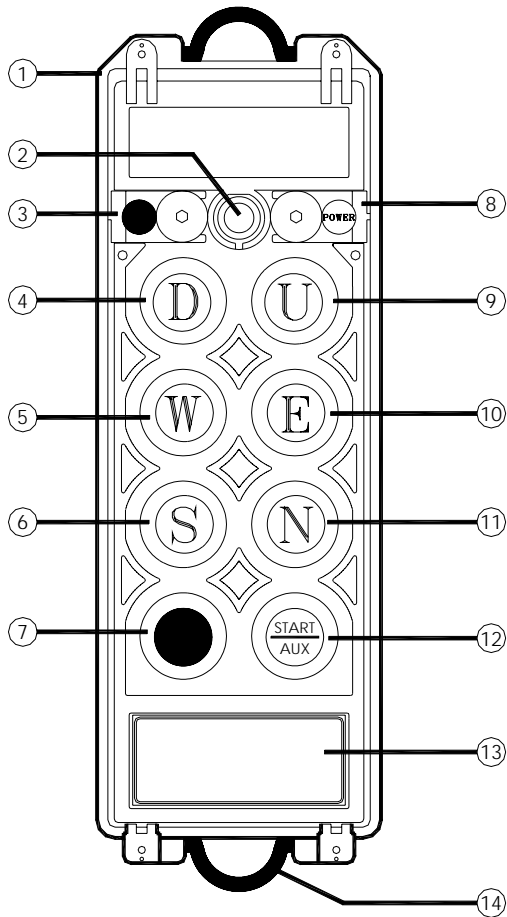

(Transmitter Front View)

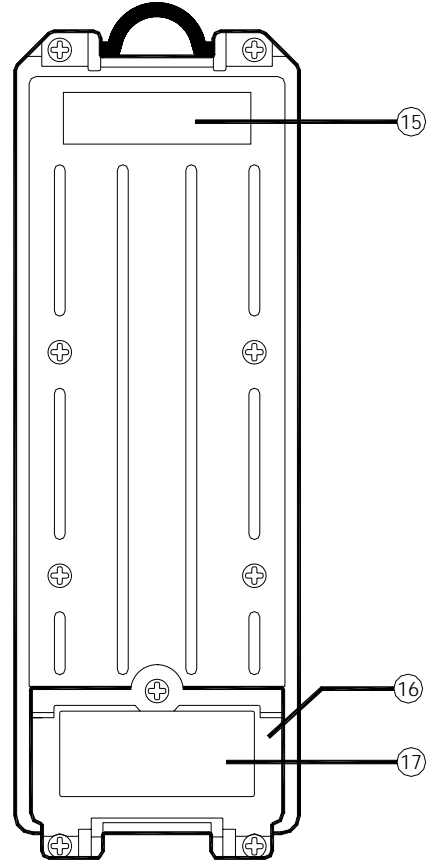

(Transmitter Back View)

- | | |
|--------------------------------|-------------------------------|
| 1. Transmitter Unit | 9. Pushbutton #1 (U or ↑) |
| 2. Status LED Display* | 10. Pushbutton #3 (E or →) |
| 3. Spare Power Key | 11. Pushbutton #5 (N or ↗) |
| 4. Pushbutton #2 (D or ↓) | 12. Pushbutton #7 (START/AUX) |
| 5. Pushbutton #4 (W or ←) | 13. Warning Label |
| 6. Pushbutton #6 (S or ↙) | 14. Shoulder Strap Ring |
| 7. Emergency Stop Button (EMS) | 15. System Information |
| 8. Power Key Switch | 16. Battery Cover |
| | 17. FCC/IC Label |

* Please refer to page 25 for transmitter Status LED display information

3.2 Alpha 3000F Models Internal Assembly

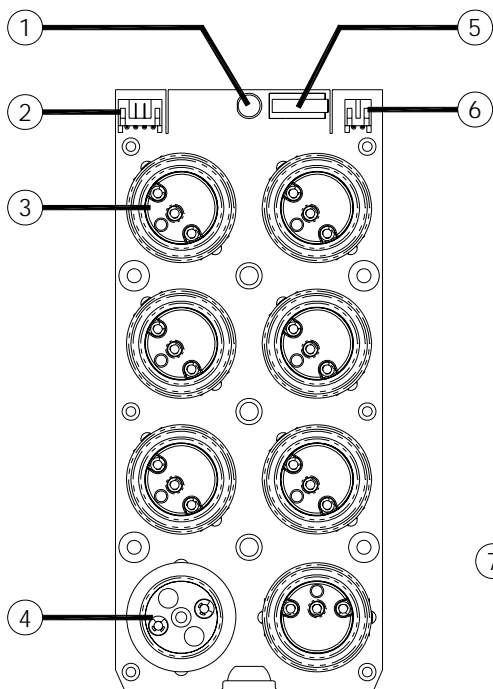

(PCB Front View)

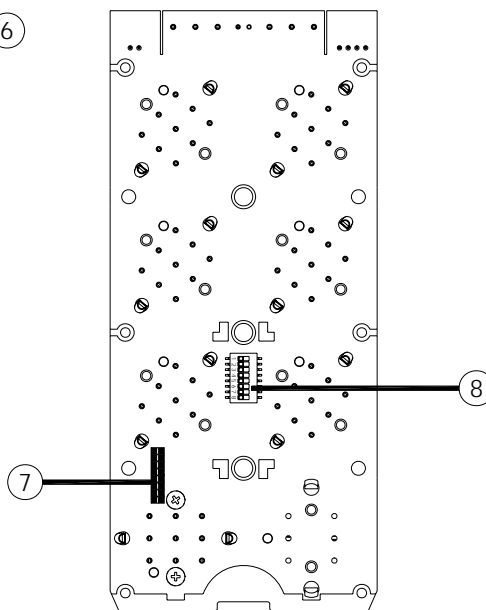

(PCB Back View)

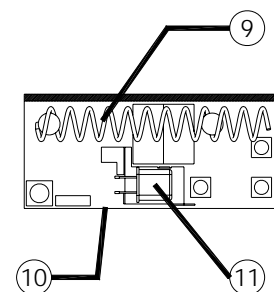

(RF Board Front View)

- | | |
|----------------------------------|---|
| 1. Status LED Display | 6. Battery Power Connector |
| 2. RF-to-Encoder Board Connector | 7. ID Code Soldering Slot (1 st ~ 8 th digit) |
| 3. 1, 2 or 3-Step Pushbuttons | 8. ID Code Dip-switch (9 th ~16 th digit) |
| 4. Emergency Stop Button (EMS) | 9. Internal Antenna |
| 5. Power ON/OFF Micro-Switch | 10. Transmitting RF Board |
| | 11. Quartz Crystal |

3.3 Alpha 3000D Models External Assembly

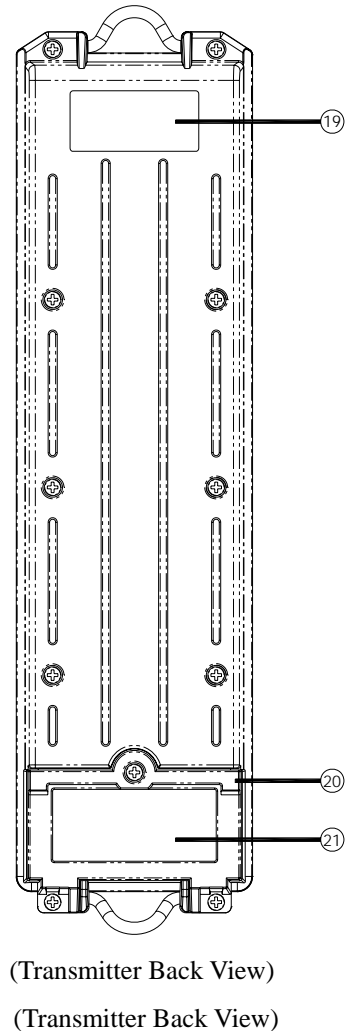
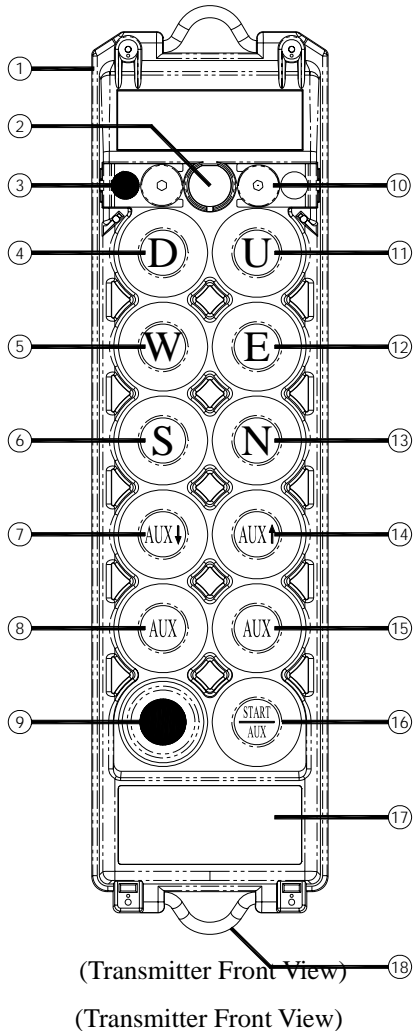

- | | |
|----------------------------------|----------------------------------|
| 1. Transmitter Unit | 11. Pushbutton #1 (U or ↑) |
| 2. Status LED Display* | 12. Pushbutton #3 (E or →) |
| 3. Spare Power Key | 13. Pushbutton #5 (N or ↗) |
| 4. Pushbutton #2 (D or ↓) | 14. Pushbutton #7 (AUX or AUX ↑) |
| 5. Pushbutton #4 (W or ←) | 15. Pushbutton #9 (AUX or AUX →) |
| 6. Pushbutton #6 (S or ↙) | 16. Pushbutton #11 (START/AUX) |
| 7. Pushbutton #8 (AUX or AUX ↓) | 17. Warning Label |
| 8. Pushbutton #10 (AUX or AUX ←) | 18. Shoulder Strap Ring |
| 9. Emergency Stop Button (EMS) | 19. System Information |
| 10. Power Key Switch | 20. Battery Cover |
| | 21. FCC/IC Label |

* Please refer to page 25 for transmitter Status LED display information

3.4 Alpha 3000D Models Internal Assembly

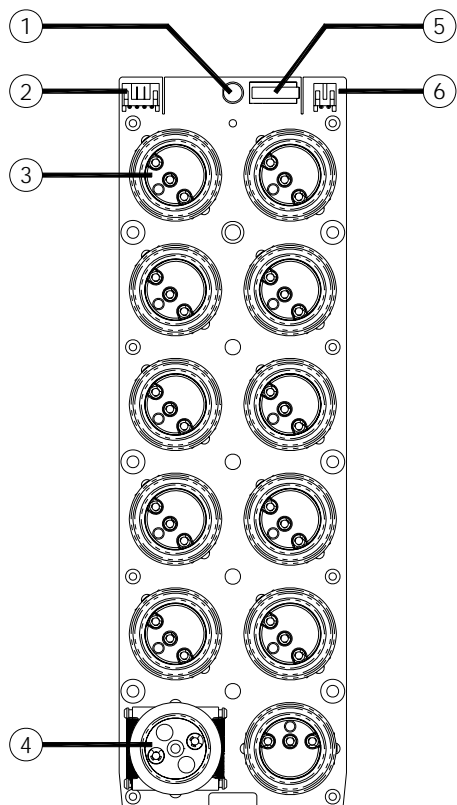

(PCB Front View)

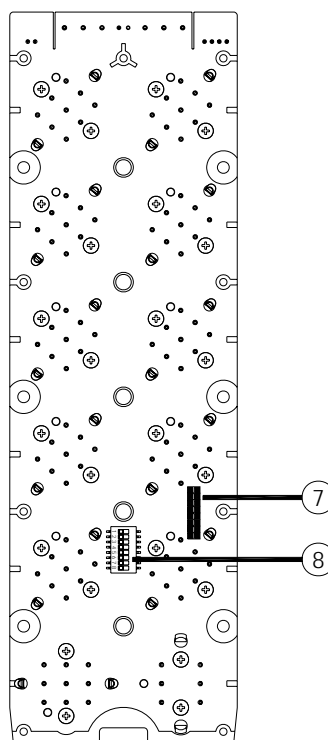

(PCB Back View)

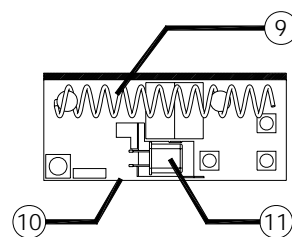

(RF Board Front View)

- | | |
|--|---|
| 1. Status LED Display | 6. Battery Power Connector |
| 2. RF Board to Encoder Board Connector | 7. ID Code Soldering Slot (1 st ~ 8 th digit) |
| 3. 1, 2 or 3-Step Pushbuttons | 8. ID Code Dip-switch (9 th ~16 th digit) |
| 4. Emergency Stop Button (EMS) | 9. Internal Antenna |
| 5. Power ON/OFF Micro-Switch | 10. Transmitting RF Board |
| | 11. Quartz Crystal |

4. RECEIVER ILLUSTRATION

4.1 External Assembly (All Models)

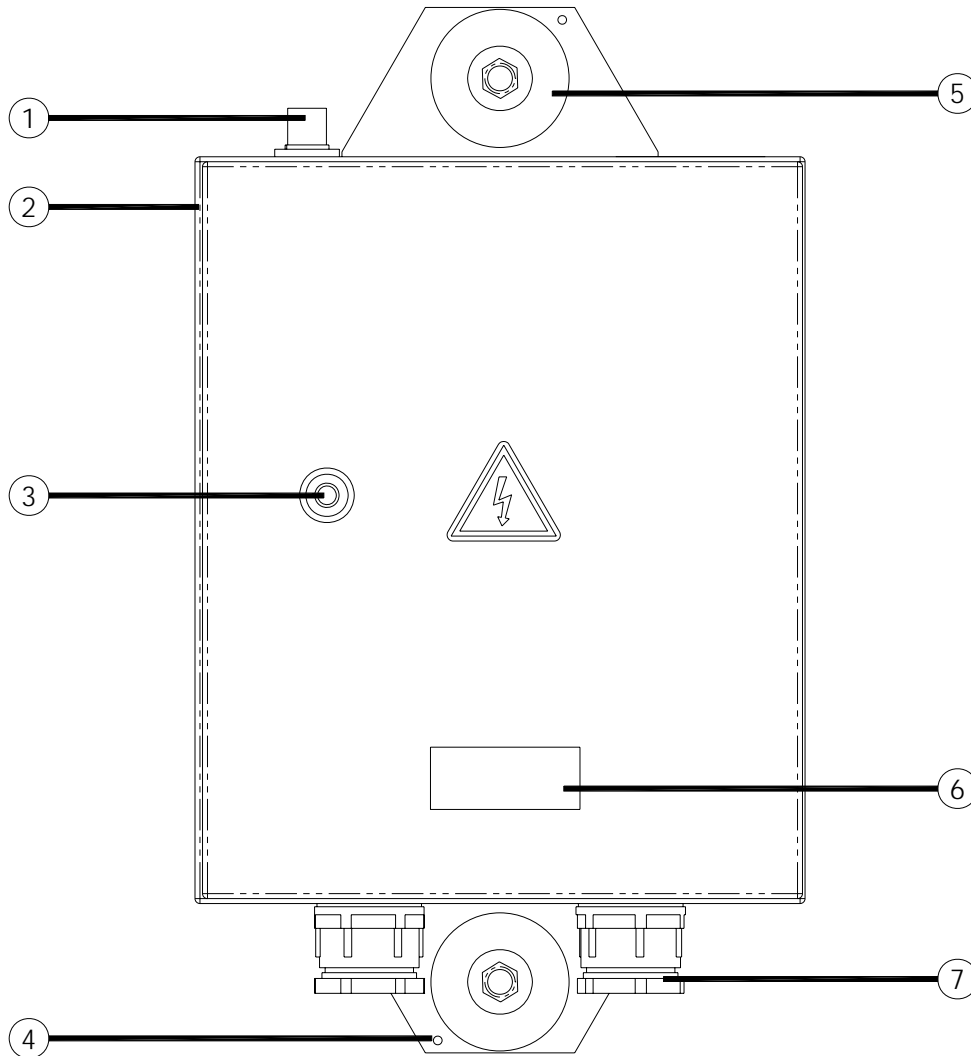

(Alpha 3000 Models Receiver External View)

- | | |
|-----------------------|----------------------------|
| 1. Antenna Seat | 4. External Grounding Hole |
| 2. Receiver Enclosure | 5. Rubber Shock Absorber |
| 3. Key Lock | 6. System Information |
| | 7. Cable Gland/Cord Grip |

4.2 Alpha 3000F Models Internal Assembly

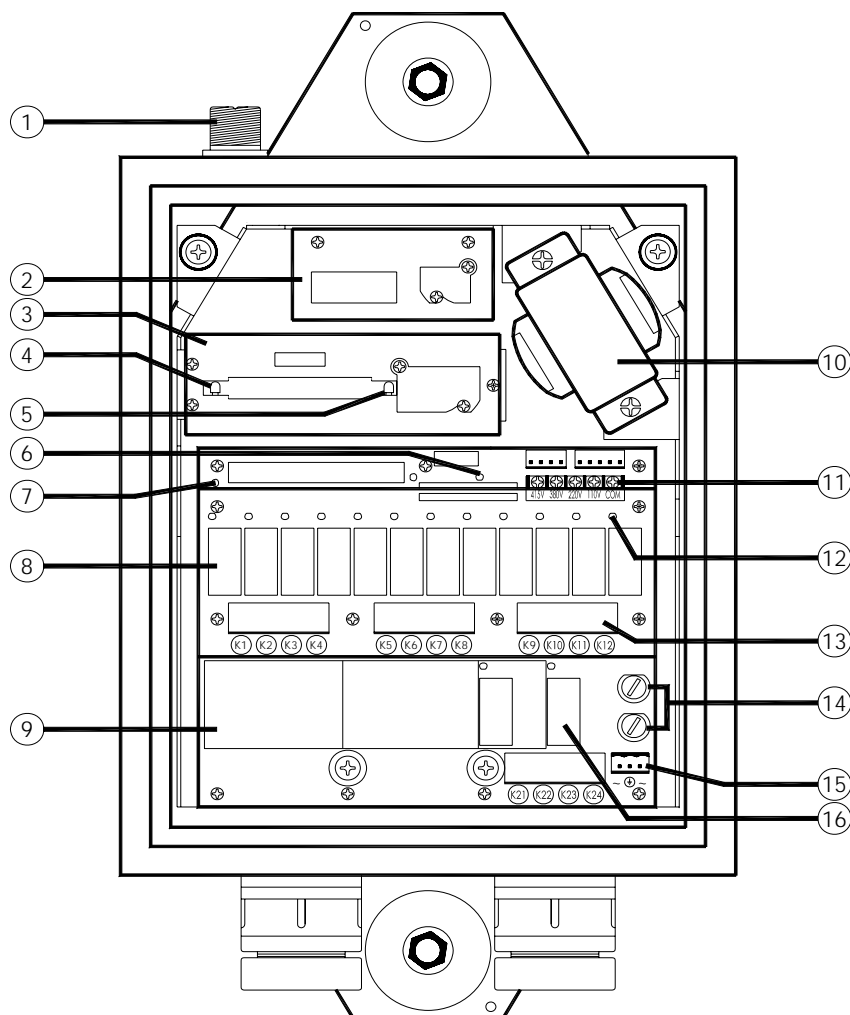

(Alpha 3000F2 & F3 Models Receiver Internal View)

- | | |
|---------------------------------|---------------------------------|
| 1. Antenna Seat | 9. Bottom Relay Board |
| 2. Receiving RF Module | 10. Power Transformer |
| 3. Decoder Module | 11. Input Voltage Selector Seat |
| 4. Decoder Module Power Display | 12. Contact Relay LED Display |
| 5. Receiver Status LED Display* | 13. Terminal Block |
| 6. SQ Status LED Display* | 14. Power Fuses (1.0A) |
| 7. Power (AC) LED Display | 15. AC Power Input |
| 8. Upper Relay Board | 16. MAIN Contact Relay |

* Please refer to page 27 for Receiver and SQ display information

4.3 Alpha 3000D Models Internal Assembly

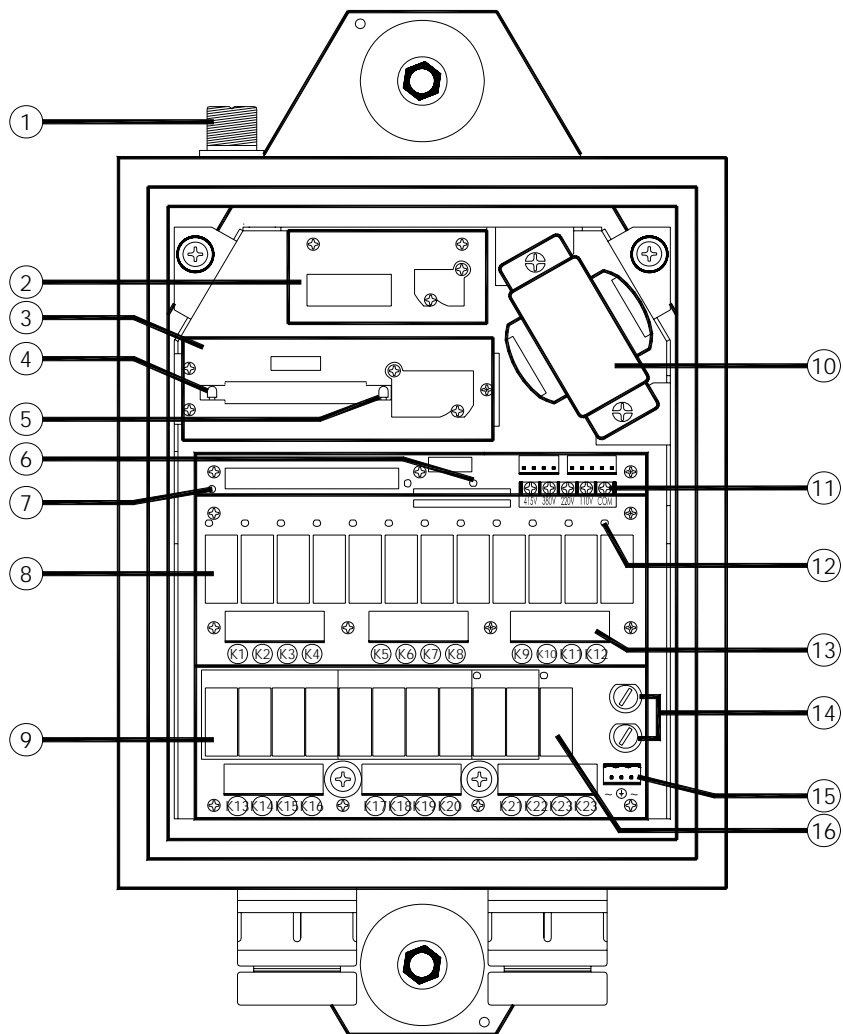

(Alpha 3000D2 & D3 Models Receiver Internal View)

- | | |
|---------------------------------|---------------------------------|
| 1. Antenna Seat | 9. Bottom Relay Board |
| 2. Receiving RF Module | 10. Power Transformer |
| 3. Decoder Module | 11. Input Voltage Selector Seat |
| 4. Decoder Module Power Display | 12. Contact Relay LED Display |
| 5. Receiver Status LED Display* | 13. Terminal Block |
| 6. SQ Status LED Display* | 14. Power Fuses (1.0A) |
| 7. Power (AC) LED Display | 15. AC Power Input |
| 8. Upper Relay Board | 16. MAIN Contact Relay |

* Please refer to page 27 for Receiver and SQ display information

5. OUTPUT CONTACT DIAGRAM

5.1 Alpha 3000F2 Output Contact

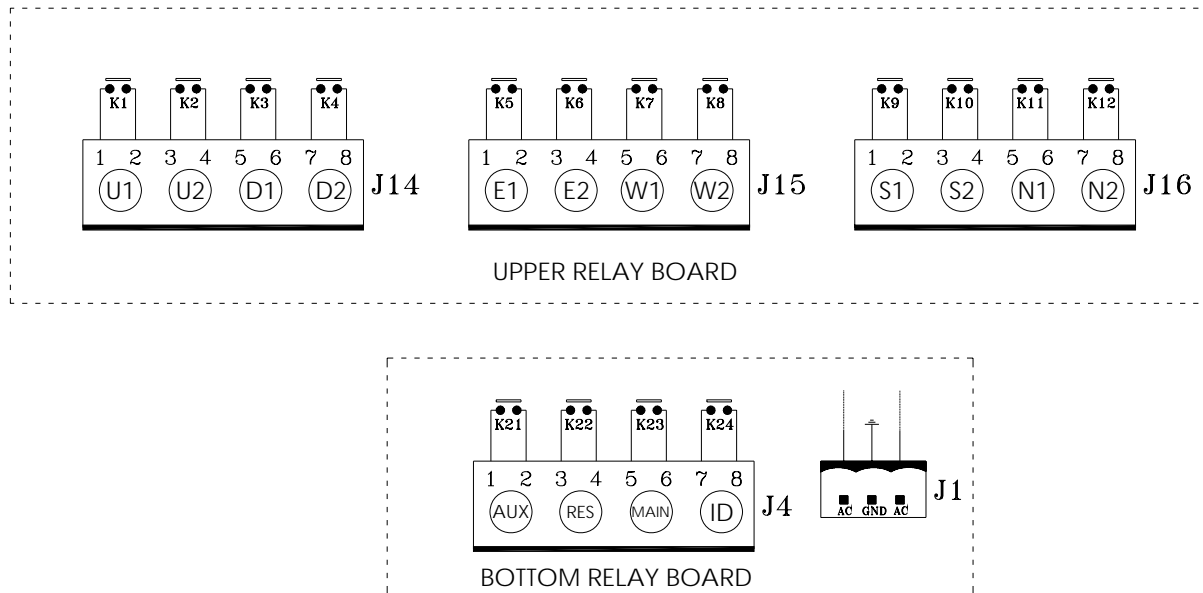

Note A: Z1 output contact represents the 7th pushbutton on the transmitter (START/AUX), which can be used for lights, horn, or other types of applications (refer to section 6.5 on page 21).

Note B: The preprinted output contact markings on the relay boards below the terminal blocks are intended for Alpha 3000F3 and Alpha 3000D3 models. If your system is an Alpha 3000F2 or an Alpha 3000D2 model, please ignore the preprinted markings and connect the wires according to the diagram above.

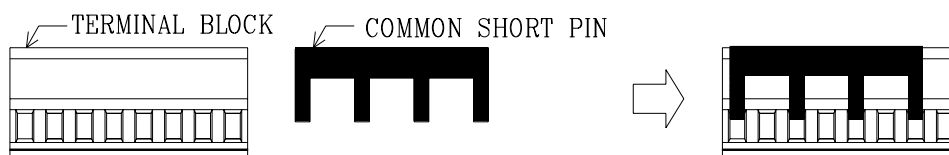

Terminal Block and Common Shorting Pin Assembly

Common shorting pin illustrated above can be used rather than “daisy chaining” wiring for the common.

5.2 Alpha 3000F3 Output Contact

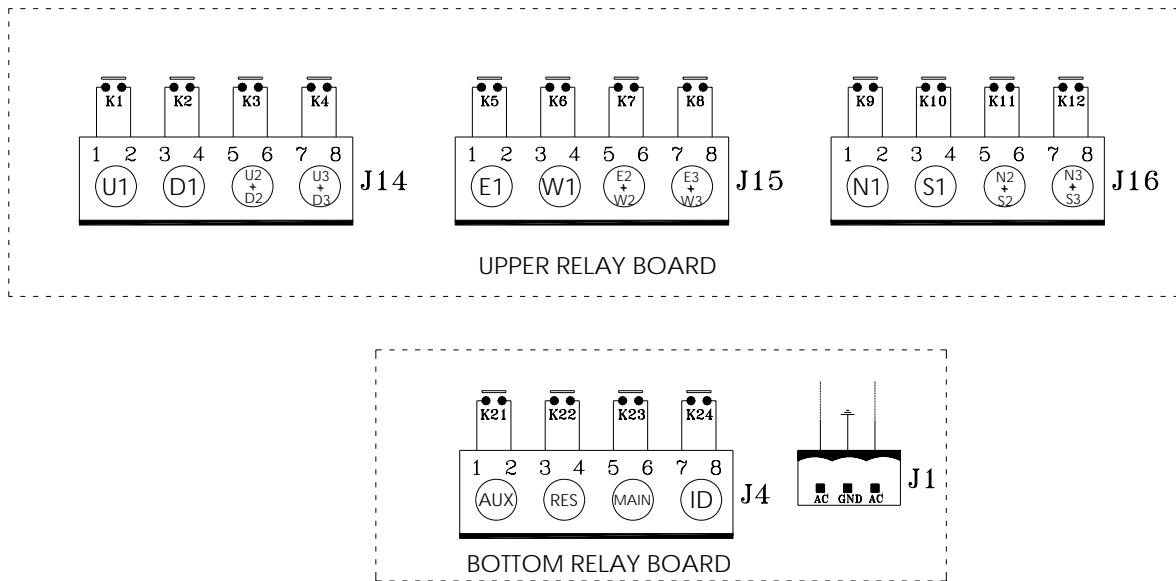

Note: Z1 output contact represents the 7th pushbutton on the transmitter (START/AUX), which can be used for lights, horn, or other types of applications (refer to section 6.5 on page 21).

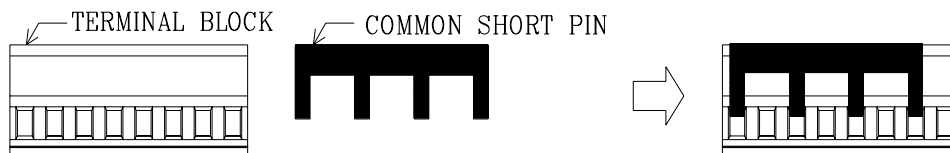

Terminal Block and Common Shorting Pin Assembly

Common shorting pin illustrated above can be used rather than “daisy chaining” wiring for the common.

5.3 Alpha 3000D2 Output Contact

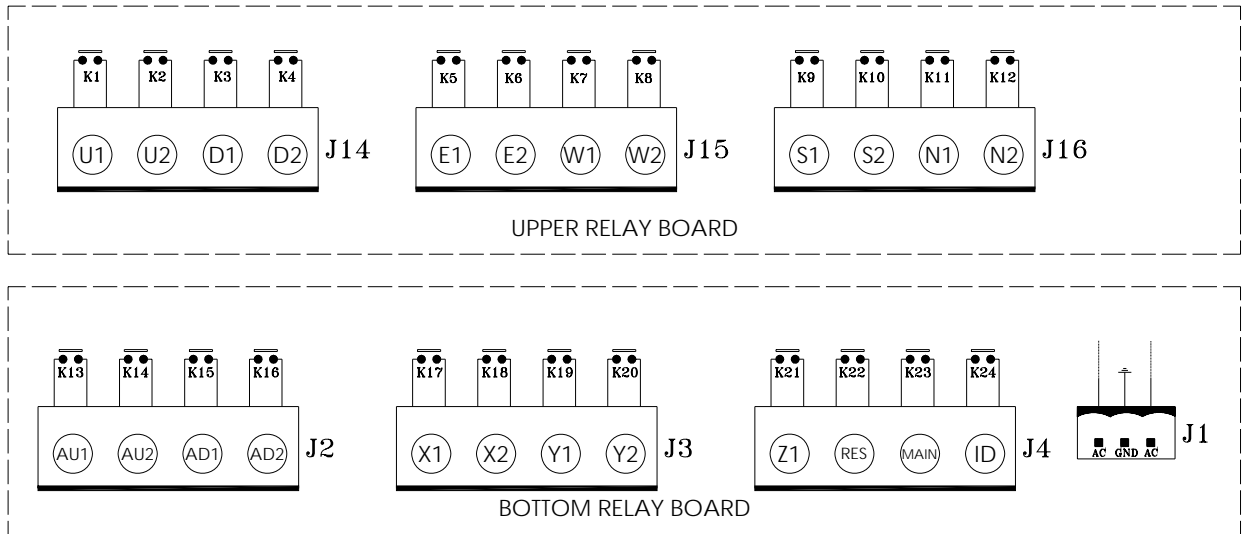

- Note A: AU & AD output contacts represent the 7th and 8th pushbuttons on the transmitter (AUX ↑ & AUX ↓), which can be used for the auxiliary hoist motion or other types of applications (refer to section 6.5 on page 21).
- Note B: X & Y output contacts represent the 9th and 10th pushbuttons on the transmitter (AUX), which can be used for the auxiliary trolley motion or other types of applications (refer to section 6.5 on page 21).
- Note C: Z1 output contact represents the 11th pushbutton on the transmitter (START/AUX), which can be used for lights, horn, or other types of applications (refer to section 6.5 on page 21).
- Note D: The preprinted output contact markings on the relay boards below the terminal blocks are intended for Alpha 3000F3 and Alpha 3000D3 models. If your system is an Alpha 3000F2 or an Alpha 3000D2 model, please ignore the preprinted markings and connect the wires according to the diagram above.

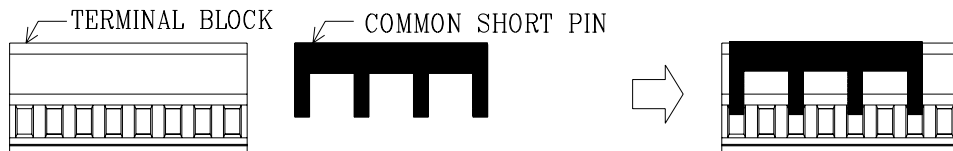

Terminal Block and Common Shorting Pin Assembly

Common shorting pin illustrated above can be used rather than “daisy chaining” wiring for the common.

5.4 Alpha 3000D3 Output Contact

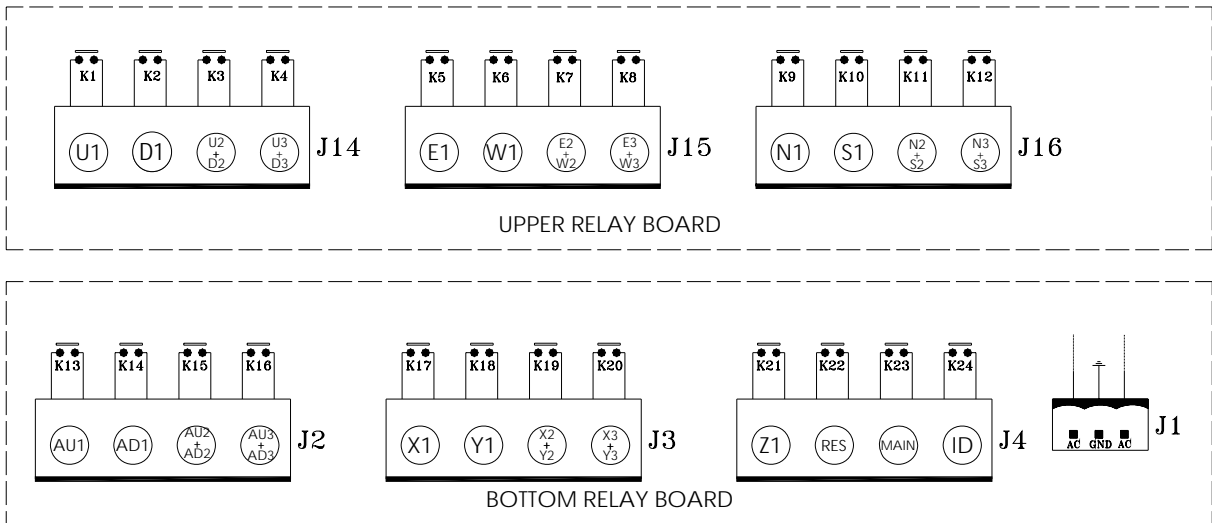

Note A: AU & AD output contacts represent the 7th and 8th pushbuttons on the transmitter (AUX ↑ & AUX ↓), which can be used for the auxiliary hoist motion or other types of applications (refer to section 6.5 on page 21).

Note B: X & Y output contacts represent the 9th and 10th pushbuttons on the transmitter (AUX), which can be used for the auxiliary trolley motion or other types of applications (refer to section 6.5 on page 21).

Note C: Z1 output contact represents the 11th pushbutton on the transmitter (START/AUX), which can be used for lights, horn, or other types of applications (refer to section 6.5 on page 21).

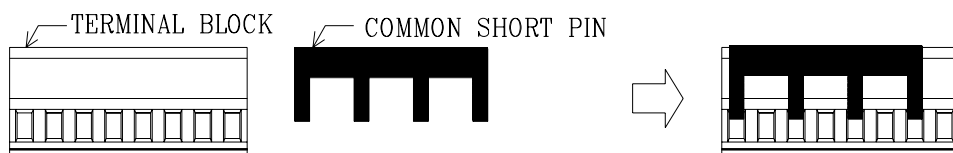

Terminal Block and Common Shorting Pin Assembly

Common shorting pin illustrated above can be used rather than “daisy chaining” wiring for the common.

6. SYSTEM CONFIGURATIONS

6.1 Jumper Settings

There are numerous functions that can be set via jumpers located inside the decoder module. Please see the diagram and chart below on how to set these functions.

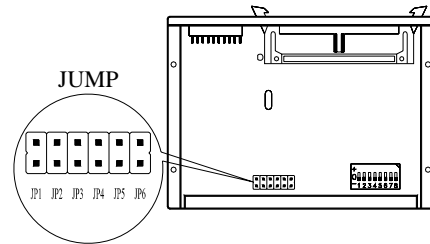

Manufacture Setting for Alpha 3000F2 & D2 Models

JP1	Open	After inserting the transmitter power key at system startup or after EMS reset, press the START/AUX button to activate the receiver MAIN relay.
	Short	Insert the transmitter power key immediately activates the receiver MAIN relay. After EMS reset, re-insert the power key to reactivate the receiver MAIN relay.
JP2	Open	After 5 minutes of transmitter non-usage the receiver MAIN relay will be deactivated.
	Short	Receiver MAIN relay stays on constantly until the main power source to the crane or equipment is turned off.
JP3	Open	Both 1 st and 2 nd speed contact relays energized (closed) when either #1 or #2 transmitter pushbutton (U or D) is pressed to the 2 nd speed.
	Short	Only the 2 nd speed contact relay is energized (closed) when either #1 or #2 transmitter pushbutton (U or D) is pressed to the 2 nd speed.
JP4	Open	Both 1 st and 2 nd speed contact relays energized (closed) when either #3 or #4 transmitter pushbutton (E or W) is pressed to the 2 nd speed.
	Short	Only the 2 nd speed contact relay is energized (closed) when either #3 or #4 transmitter pushbutton (E or W) is pressed to the 2 nd speed.
JP5	Open	Both 1 st and 2 nd speed contact relays energized (closed) when either #5 or #6 transmitter pushbutton (N or S) is pressed to the 2 nd speed.
	Short	Only the 2 nd speed contact relay is energized (closed) when either #5 or #6 transmitter pushbutton (N or S) is pressed to the 2 nd speed.

Note: Every time when you change jumper settings please make sure to turn the receiver power "off" and then back "on" again so that the newly selected functions can be stored in memory.

Top Location → “1”
 Bottom Location → “0”

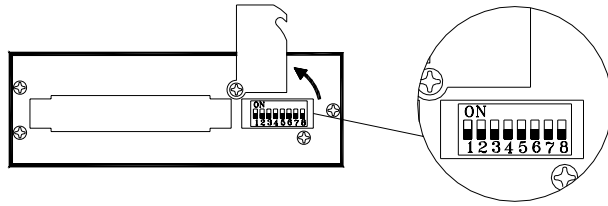

Manufacture Setting for Alpha 3000D2 Model

DIP-8	“0”	Both 1 st and 2 nd speed contact relays energized (closed) when either #7 or #8 transmitter pushbutton (AUX ↑ or AUX ↓) is pressed to the 2 nd speed.
	“1”	Only the 2 nd speed contact relay is energized (closed) when either #7 or #8 transmitter pushbutton (AUX ↑ or AUX ↓) is pressed to the 2 nd speed.

Note: Every time when you change dip-switch settings please make sure to turn the receiver power “off” and then back “on” again so that the newly selected functions can be stored in memory.

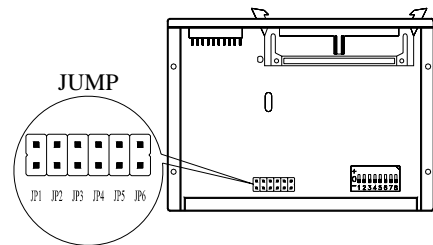

Manufacture Setting for Alpha 3000F3 & D3 Models

JP1	Open	After inserting the transmitter power key at system startup or after EMS reset, press the START/AUX button to activate the receiver MAIN relay.
	Short	Insert the transmitter power key immediately activates the receiver MAIN relay. After EMS reset, re-insert the power key to reactivate the receiver MAIN relay.
JP2	Open	After 5 minutes of transmitter non-usage the receiver MAIN relay will be deactivated.
	Short	Receiver MAIN relay stays on constantly until the main power source to the crane or equipment is turned off.
JP3	Open	Pushbutton #1 through #6 interlocked (U/D, E/W, N/S).
	Short	Pushbutton #1 through #6 non-interlocked with single-speed relay contact.
JP4	Open	No acceleration delay from 1 st through 3 rd speed
	Short	Acceleration delay for up to 1 second from 1 st through 3 rd speed

Note: Every time when you change jumper settings you must first turn the receiver power “off” and then turn it back “on” after setting so that they can be stored in memory.

JP1 (For all models)

JP1 Open	Insert the transmitter power key	Press and hold START/AUX	Receiver MAIN activated	OR	After EMS reset	Press and hold START/AUX	Receiver MAIN activated
JP1 Short	Insert the transmitter power key	Receiver MAIN activated	OR	After EMS reset	Re-insert the transmitter power key		Receiver MAIN activated

JP2 (For all models)

JP2 Open	5 minutes of transmitter non-usage	Receiver MAIN deactivated	Press any pushbuttons	Receiver MAIN reactivated
JP2 Short	Receiver MAIN stays “on” constantly until the main power source to the system is turn “off”			

JP3 (For Alpha 3000F2 & 3000D2 models only)

JP3 Open	Press #1 or #2 (U or D) pushbutton down to the 1 st speed	1 st speed contact relay engaged (closed)	Press #1 or #2 (U or D) pushbutton down to the 2 nd speed	Both 1 st and 2 nd speed contact relays engaged (closed)
JP3 Short	Press #1 or #2 (U or D) pushbutton down to the 1 st speed	1 st speed contact relay engaged (closed)	Press #1 or #2 (U or D) pushbutton down to the 2 nd speed	Only the 2 nd speed contact relay is engaged (closed)

JP3 (For Alpha 3000F3 & 3000D3 models only)

JP3 Open	Pushbutton 1 through 6 interlocked			
JP3 Short	Pushbutton 1 through 6 non-interlocked with each pushbutton becomes single-speed contact			

JP4 (For Alpha 3000F2 & 3000D2 models only)

JP4 Open	Press #3 or #4 (E or W) pushbutton down to the 1 st speed	1 st speed contact relay engaged (closed)	Press #3 or #4 (E or W) pushbutton down to the 2 nd speed	Both 1 st and 2 nd speed contact relays engaged (closed)
JP4 Short	Press #3 or #4 (E or W) pushbutton down to the 1 st speed	1 st speed contact relay engaged (closed)	Press #3 or #4 (E or W) pushbutton down to the 2 nd speed	Only the 2 nd speed contact relay is engaged (closed)

JP4 (For Alpha 3000F3 & 3000D3 models only)

JP4 Open	No acceleration delay from 1 st through 3 rd speed									
JP4 Short	1 st speed depressed	After 1 second	1 st speed contact relay engaged	2 nd speed depressed	After 1 second	2 nd speed contact relay engaged	3 rd speed depressed	After 1 second	3 rd speed contact relay engaged	

JP5 (For Alpha 3000F2 & 3000D2 models only)

JP5 Open	Press #5 or #6 (N or S) pushbutton down to the 1 st speed	1 st speed contact relay engaged (closed)	Press #5 or #6 (N or S) pushbutton down to the 2 nd speed	Both 1 st and 2 nd speed contact relays engaged (closed)
JP4 Short	Press #5 or #6 (N or S) pushbutton down to the 1 st speed	1 st speed contact relay engaged (closed)	Press #5 or #6 (N or S) pushbutton down to the 2 nd speed	Only the 2 nd speed contact relay is engaged (closed)

Dip-8 (For Alpha 3000D2 model only)

DIP-8 “0”	Press #7 or #8 (AUX ↑ or AUX ↓) pushbutton down to the 1 st speed	1 st speed contact relay engaged (closed)	Press #7 or #8 (AUX ↑ or AUX ↓) pushbutton down to the 2 nd speed	Both 1 st and 2 nd speed contact relays engaged (closed)
DIP-8 “1”	Press #7 or #8 (AUX ↑ or AUX ↓) pushbutton down to the 1 st speed	1 st speed contact relay engaged (closed)	Press #7 or #8 (AUX ↑ or AUX ↓) pushbutton down to the 2 nd speed	Only the 2 nd speed contact relay is engaged (closed)

6.2 Security ID Code Settings

Transmitter ID code can be readjusted via an 8-position soldering slot (the first 8 digits of the ID code) and an 8-position dip-switch (the last 8 digits of the ID code). Please refer to item # 7 on page 5 and item # 8 on page 7 for the location of the soldering slot and dip-switch on the encoder board. As for the receiver ID code setting, the soldering slot and the dip-switch are located inside the decoder module; please refer to item #3 on page 9 & 10 and below illustration.

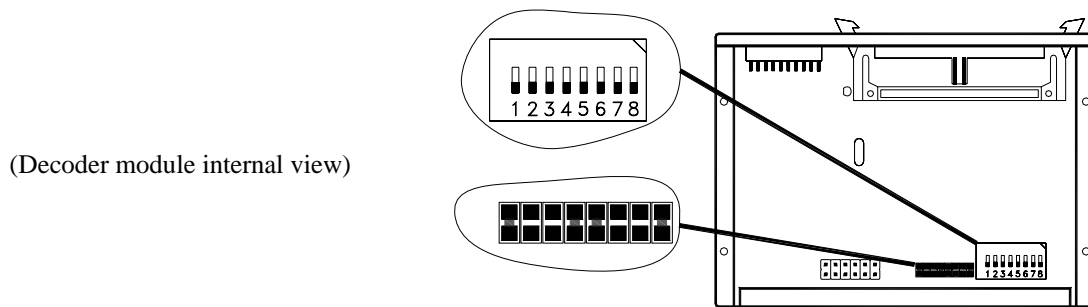

Please note the first 8-digit of the ID code can be changed or altered simply by soldering the two contact points together ("1" value); the position is at "0" value when unsoldered (two points open). The last 8-digit ID code is set via an 8-position dip-switch located next to the 8-position soldering slot.

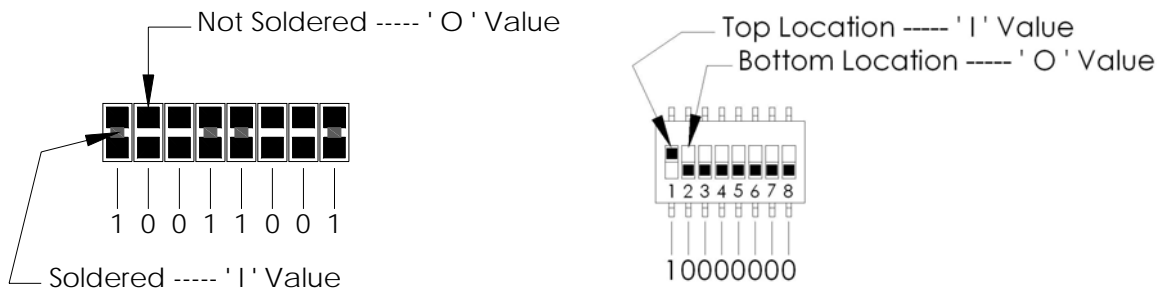

Due to Alpha 3000 series' ID code (or address code) is 16-digit long, the first 8 digits are set via the soldering slot and the remaining last 8 digits are set via the dip-switch (total of 16 digits). For the soldering slot, the "SH8" represents the 1st digit of the ID code and "SH15" represents the 8th digit of the ID code. As for the dip-switch, the "1" represents 9th digit of the ID code and the "8" represents the 16th digit of the ID code (last digit). Next page are some sample illustrations for better understanding on how to set the entire 16-digit ID code via the soldering slot and the dip-switch.

Example 1:

ID code 00000000:10101010

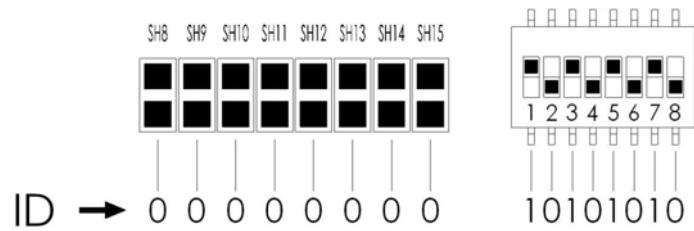

Example 2:

ID code 01011001:00011100



6.3 Frequency (RF) Channel Settings

All Alpha 3000 systems are also equipped with a PLL synthesized receiving RF module with up to 30 user-adjustable RF channels. The RF channel dip-switch is located on the topside of the receiving RF module, covered by a sliding door (refer to item #2 on page 9 & 10).

Example: For the below illustrated dip-switch “**00101**” setting, counting from dip-position #1 through #5, the RF channel would be “**205**”, which also represents frequency “**301.205 MHz**”. Please refer to the Frequency (RF) Channel Table next page or the CHANNEL → DIP label inside the receiver door panel.

Top Location → “1”
 Bottom Location → “0”

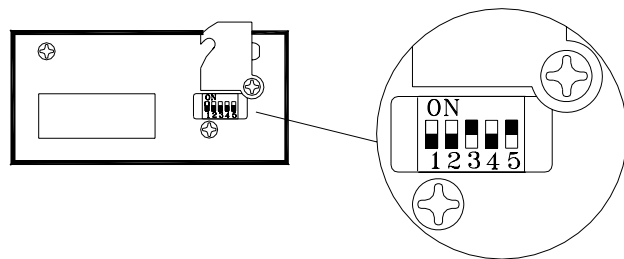

6.4 Frequency (RF) Channel Table

FREQUENCY	DIP-SWITCH SETTING	RF CHANNEL
301.105 MHz	00001	201
301.130 MHz	00010	202
301.155 MHz	00011	203
301.180 MHz	00100	204
301.205 MHz	00101	205
301.230 MHz	00110	206
301.255 MHz	00111	207
301.280 MHz	01000	208
301.305 MHz	01001	209
301.330 MHz	01010	210
301.355 MHz	01011	211
301.380 MHz	01100	212
301.405 MHz	01101	213
301.430 MHz	01110	214
301.455 MHz	01111	215
301.480 MHz	10000	216
301.505 MHz	10001	217
301.530 MHz	10010	218
301.555 MHz	10011	219
301.580 MHz	10100	220
301.605 MHz	10101	221
301.630 MHz	10110	222
301.655 MHz	10111	223
301.680 MHz	11000	224
301.705 MHz	11001	225
301.730 MHz	11010	226
301.755 MHz	11011	227
301.780 MHz	11100	228
301.805 MHz	11101	229
301.830 MHz	11110	230

6.5 Pushbutton Contact Settings

There are numerous pushbutton functions that can be programmed via an 8-position dip-switch located on the decoder module (refer to the diagram below). By adjusting each dip setting either to the top or bottom location will change the contact form of the intended pushbutton (refer to the chart below). Transmitter pushbuttons are numbered from right-to-left and then from top-to-bottom.

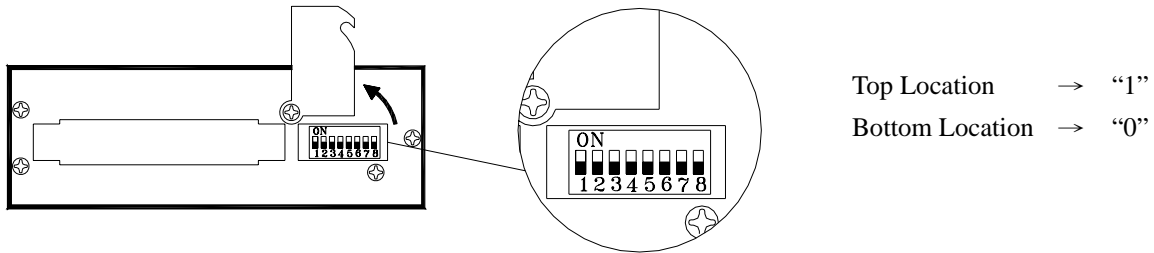

Alpha 3000F Models	DIP1 → “0” → Pushbutton #7 (START/AUX) with momentary relay contact “1” → Pushbutton #7 (START/AUX) with latching relay contact
Alpha 3000D Models	DIP1 → “0” → Pushbutton #11 (START/AUX) with momentary relay contact “1” → Pushbutton #11 (START/AUX) with latching relay contact DIP2 → “0” → Pushbutton #7 & #8 interlocked “1” → Pushbutton #7 & #8 non-interlocked DIP3 → “0” → Pushbutton #7 with momentary relay contact* “1” → Pushbutton #7 with latching relay contact* * DIP2 must set to “1” DIP4 → “0” → Pushbutton #8 with momentary relay contact* “1” → Pushbutton #8 with latching relay contact* * DIP2 must set to “1” DIP5 → “0” → Pushbutton #9 & #10 interlocked “1” → Pushbutton #9 & #10 non-interlocked DIP6 → “0” → Pushbutton #9 with momentary relay contact* “1” → Pushbutton #9 with latching relay contact* * DIP5 must set to “1” DIP7 → “0” → Pushbutton #10 with momentary relay contact* “1” → Pushbutton #10 with latching relay contact* * DIP5 must set to “1” DIP8 → Refer to page 16

6.6 Voltage Settings

There are four different voltage settings available inside the Alpha 3000 receiver located next to the bottom relay board, please select one that corresponds to the main power source of the crane or equipment.

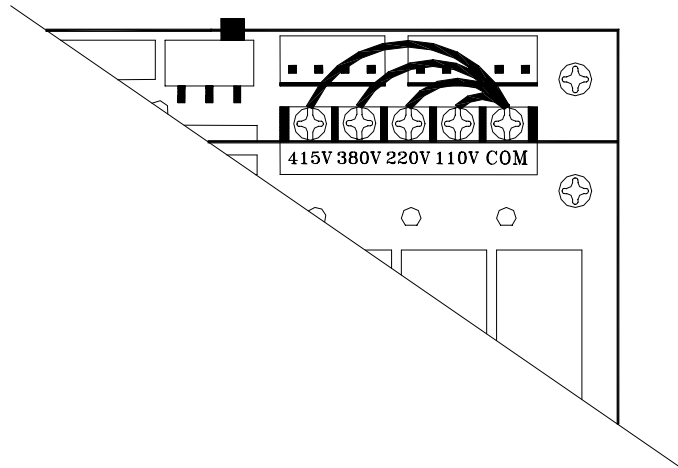

Power Transform Available:

SSB-2181 → 48VAC / 220VAC / 0ACV / 460VAC @ 50/60Hz.

SSB-1726 → 110VAC / 220VAC / 380VAC / 415VAC @ 50/60Hz.

SSB-2213 → 115VAC / 208VAC / 230VAC / 460VAC @ 50/60Hz.

Note A: When different voltage setting is selected, make sure that one end of the wire is connected to the COM position and the other end connected to the voltage position that corresponds to the main power source of the crane or equipment. Also make sure that all screws are tightened prior to turning “on” the main power supply.

Note B: If the receiver system does not respond when the main power source is turn on, then turn the power off and check for any burned or open fuse.

7. RECEIVER INSTALLATION

7.1 Preparation For Installation

1. Required Tools:
 - (1) Flat Head Screwdriver (-)
 - (2) Phillips Head Screwdriver (+)
 - (3) Multi-Meter
 - (4) Open End Wrench
 - (5) Power Drill with 10.5mm ~ 11mm Drill-Bit
2. Check to ensure that your receiver is not set to the same RF channel and ID code as any other systems in operation at the same facility or within distance of 900 feet.
3. Prior to installation, make sure that the crane or equipment itself is working properly.
4. Use a multi-meter to check the voltage source available and ensure that the receiver voltage setting matches your power source.
5. Prior to installation, switch “off” the main power source to the crane or equipment.
6. All pole mains switch or circuit breaker with a contact separation of at least 3 mm in each pole, shall be incorporated in the electrical installation of the building to ensure the possibility of complete disconnection of the apparatus from the mains, if necessary.

7.2 Step-By-Step Installation

1. The location selected should have the antenna visible from all areas where the transmitter is to be used.
2. The location selected should not be exposed to high levels of electrical noise.
3. Ensure the selected location has adequate space to accommodate the receiver enclosure.
4. Make sure the receiver unit is in upright position (vertical).
5. The distance between the antenna and the control panel should be as far apart as possible.
6. Drill two holes on the control panel (10.5mm). Refer to diagrams next page.
7. Tightened the bolt nuts provided.
8. **Ensure AC ground is connected to the power input terminal block otherwise chassis ground should be connected to the chassis ground connection hole on the receiver enclosure (refer to item #4 on page 8).**
9. For system wiring, please refer to the output contact diagram on page 11~14.
10. Ensure all wiring is correct and safely secured and all screws are fastened.

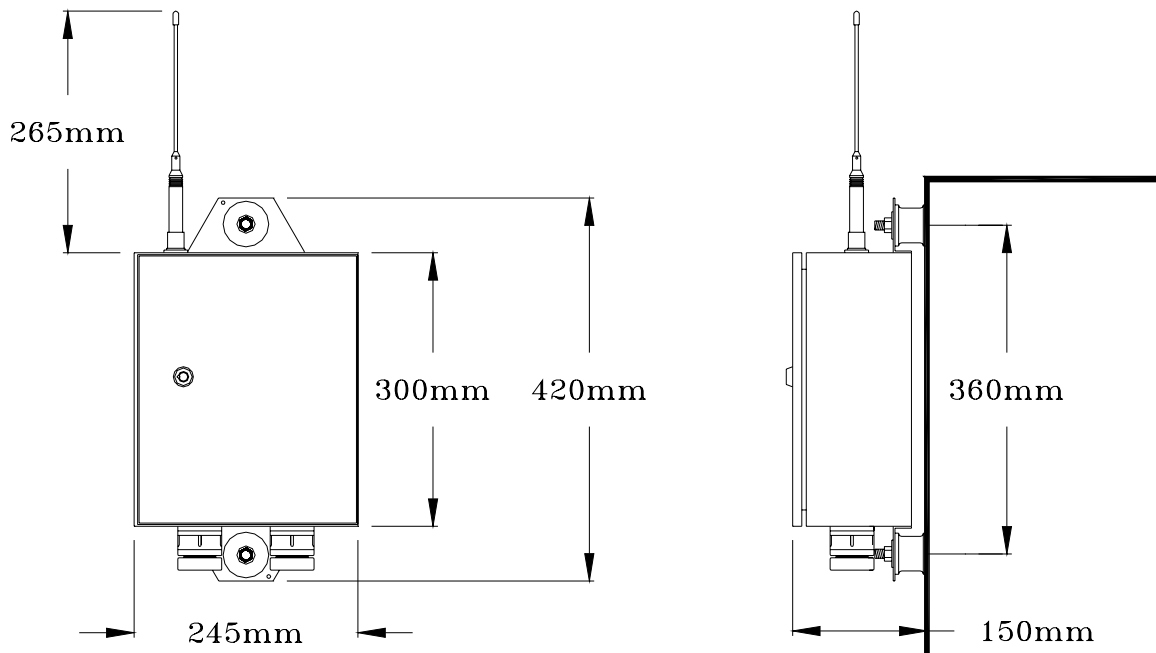

7.3 System Testing

1. Connect the power source to the receiver and test the MAIN relay output (red EMS button) and observe that it properly opens and closes the main line.
2. Test the operation of each function to ensure it corresponds to the transmitter direction labels and/or the pendant it is replacing.
3. Test the limit switches on the crane and verify that they are working properly.
4. If your new remote control is replacing an existing pendant make sure it is completely disconnected to prevent unwanted control commands.
5. If your new remote control is replacing an existing pendant make sure the pushbutton is stored in a safe location where it will not interfere with remote operation.

8. TRANSMITTER OPERATION

- Batteries** _ Make sure the four “AA” alkaline batteries are installed correctly, the labels on the battery holder will tell you which side is “up” and which side is “down”. Use 2,000mA alkaline type batteries for optimum operating time between replacements. If rechargeable batteries are used, for optimum operating time between replacements, select ones rated above 1,600mA.
- Startup Procedure** _ Make sure that the red EMS button is elevated prior to inserting the transmitter power key, by pulling it upward. Then insert the power key into the key-slot located on the top right-hand side of the transmitter handset (refer to diagram to the right). The transmitter status LED on the top-center location of the transmitter will display a constant green light for up to 2 seconds when the power key is inserted. Then press and hold the START/AUX pushbutton for up to 1.0 second to activate the receiver MAIN contact relay (depending on JP1 setting on page 15 & 16). Thereafter, the START/AUX pushbutton will become an auxiliary function, which can be used for light, horn, or other type of external application. When the command pushbutton is depressed, a blinking green light is displayed on the status LED telling the operator that the command signal is being sent to the receiver. Please refer to the table below for transmitter status LED display information.
- Transmitter Status LED Display (refer to item #2 on page 4 & 6)**

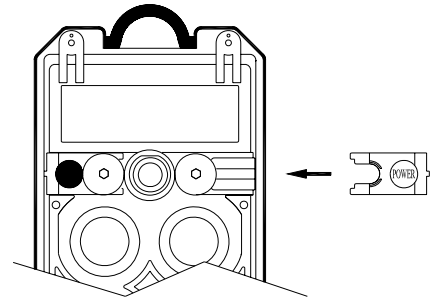

TYPE	LED DISPLAY	INDICATION
1	Green “on” → 2.0 seconds	Transmitter power “on”
2	Green “on” → 0.1 second “off” → 2.0 seconds	Pushbutton depressed with signal transmitted
3	Red “on” → 0.1 second “off” → 2.0 seconds	Transmitter low-voltage warning
4	2 fast red blinks followed by 2 seconds “off”	Pushbutton contact jammed or defective
5	Red “on” → 0.5 second “off” → 0.5 second	Emergency stop button activated (button depressed)

- Receiver Main Relay Deactivates in 5 Minutes** _ Your receiver MAIN contact relay is programmed to drop (open) the “Main Line Disconnect Contactor” after 5 minutes of inactivity, that is 5 minutes after the last pushbutton is released. Pressing any pushbutton will close the MAIN relay and start the timing sequence over again. If your crane or hoist is equipped with VFD drive this can sometimes cause an unacceptable delay. In this situation we suggest you remove the JP2 jumper (refer to JP2 setting on page 15 & 16) then the MAIN relay will remain closed until the “Stop” command is received or the main power source to the crane or equipment is turned off.
- EMS & Restarting** _ In case of an emergency, pressing down the red EMS button will immediately deactivate the receiver MAIN relay. When EMS button is activated (button depressed), the transmitter status LED will display a red blinking lights that is “on” → 0.5 second and “off” → 0.5 second (refer to the chart on page 25). To reactivate the receiver MAIN relay, just pull up the red EMS button and then press and hold the START/AUX pushbutton for up to 1.0 second (depending on JP1 setting on page 15 & 16).

6. **Interlocking Pushbuttons** _ For both 3000F & 3000D models the top 3 sets of motions (pushbutton #1 ~ #6) are interlocked to its self so no conflicting commands can take place for safety purpose. For example, pressing the Hoist “UP” and Hoist “DOWN” pushbutton (pushbutton #1 & #2) simultaneously will result in no command being sent.
7. **Initial Start-up Code** _ Please note that if JP1 is shorted (without START function) the receiver unit hence must received an “**Initial Startup Code**” from the transmitter in order for its MAIN relay to be energized (closed). What this means is that the transmitter can only activate the receiver MAIN relay as long as the operator is within the receiving range of 300 feet. For example, if the operator turns “on” the transmitter in a different area of the facility (beyond 300 feet from the receiver location), then he would not be able to control the crane when he approaches within 300 feet. If this happens, the operator would have to resent the initial startup code by reenact the Startup Procedure, within 300 feet distance from the receiver location.
8. **Shutting Off the Transmitter** _ To disconnect the transmitter power, just pull out the transmitter power key. It is also recommended that prior to disconnecting the transmitter power, also activate the emergency stop by pressing down the red EMS button, this will deactivate the receiver MAIN relay. After the red EMS button is depressed, then pull out the transmitter power key. Please note that if the transmitter power key is not pulled out after EMS activation, then the transmitter will continued to send the “Stop” command to the receiver until the transmitter power is completely drained. Also, if the red EMS button is not depressed prior to disconnecting the transmitter power, then the receiver MAIN relay will stay energized (closed) for up to 5 minutes. After 5 minutes of inactivity the receiver MAIN relay will be disengaged (open); depending on JP2 setting on page 15 & 16.
9. **Battery Replacement** _ The transmitter Status LED will display a blinking red light that is “on” 0.1 second and off “2.0 seconds when the transmitter battery power falls below the safety operating voltage, please refer to the table on page 25 for transmitter status LED display information. For battery replacement, just unscrew the battery cover located on the backside of the transmitter handset with a (+) head screwdriver (refer to the diagram below). When changing batteries, do make sure that the batteries are installed correctly. The marking inside the battery holder will tell you which side is positive (+) and which side is negative (-). The battery holder will also tell you which side of the holder is facing up and which side is down.

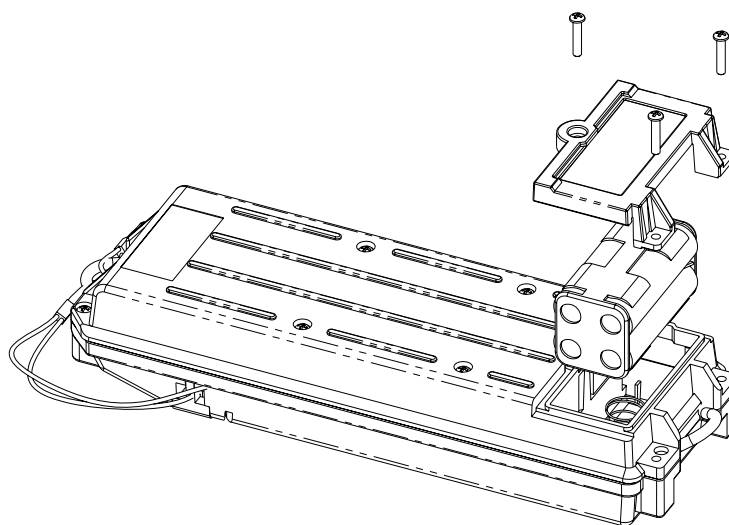

9. TROUBLE SHOOTING

Should the operator find the equipment not operating normally, please check the chart below for simple trouble shooting tips.

PROBLEM	POSSIBLE REASON	SOLUTION
Transmitter does not communicate to receiver.	Transmitter and the receiver are not on the same RF channel (SQ not lit) or ID code.	Ensure the correct transmitter is in use. The labels on the receiver and the transmitter will identify the RF channel and ID code in use.
Transmitter does not communicate to receiver.	Low or no transmitting power from the transmitter unit.	Turn on the transmitter with EMS button elevated. If the status LED displayed a blinking red lights or no lights at all, then turn the power off and replace the four batteries.
No power to the receiver.	Blown fuse or no input power connection.	Ensure power input to the receiver unit is correct. If power indicator (AC) is not lit, please check the receiver for any open fuse.
Outputs do not operate correctly.	Receiver configuration and output wiring is not set properly.	Please refer to section 5 and 6 to ensure receiver is correctly wired and configured for your application.

Receiver Status LED Display (refer to item #5 on page 9 & 10)

TYPE	LED INDICATION	PROBLEM AND SOLUTION
1	3 fast blinks followed by OFF → 2.0 seconds	Defective MAIN contact relay.
2	2 fast blinks followed by OFF → 2.0 seconds	Incorrect ID code setting, please refer to section 6.2.
3	ON → 0.1 second OFF → 2.0 seconds	Decoder on standby.
4	ON → 0.1 second OFF → 0.1 second	Transmitted signal decoded.

SQ Status LED Display (refer to item #6 on page 9 & 10)

TYPE	LED INDICATION	PROBLEM AND SOLUTION
1	ON → 0.1 second OFF → 0.1 second	Transmitted signal received by the receiver.
2	Blinking when transmitter pushbuttons are not depressed	Strong radio interference encountered.

10. **SYSTEM SPECIFICATION**

Transmitter Unit

Frequency Range	:	301 MHz
Transmitting Range	:	300 feet
Hamming Distance	:	≥ 6
Channel Spacing	:	25KHz
Frequency Control	:	Quartz Crystals
Frequency Drift	:	$< 5\text{ppm @ } -13^{\circ}\text{F} \sim 158^{\circ}\text{F}$
Frequency Deviation	:	$< 1\text{ppm @}$
Spurious Emission	:	-50dB
Transmitting Power	:	$\sim 0.3\text{mW}$
Emission	:	F1D
Antenna Impedance	:	50 ohms
Enclosure Rating	:	IP-66
Source Voltage	:	DC 6.0V
Current Drain	:	8mA @ 6V
Operating Temperature	:	$-13^{\circ}\text{F} \sim 158^{\circ}\text{F}$
Dimension	:	9.0cm x 3.0cm x 1.85cm (Alpha 3000F Models) 11.5cm x 3.0cm x 1.85cm (Alpha 3000D Models)
Weight (include batteries)	:	21.0oz (Alpha 3000F Models) 25.7oz (Alpha 3000D Models)

Receiver Unit

Frequency Range	:	301 MHz
Modulation	:	Narrow Band FM
Frequency Control	:	Synthesizer (PLL)
Frequency Drift	:	$< 5\text{ppm @ } -13^{\circ}\text{F} \sim 158^{\circ}\text{F}$
Frequency Deviation	:	$< 1\text{ppm}$
Sensitivity	:	-122dBm
Antenna Impedance	:	50ohms
Data Decoder Reference	:	Quartz Crystals
Responding Time	:	64~100mS
Enclosure Rating	:	IP-66
Source Voltage	:	AC 110V/220V/380V/415V @ 50/60 Hz.
Power Consumption	:	11VA
Operating Temperature	:	$-13^{\circ}\text{F} \sim 158^{\circ}\text{F}$
Output Contact Rating	:	250V @ 10A
Dimension	:	16.7cm x 9.6cm x 5.1cm (All Models)
Weight (include antenna)	:	17.7lb (All Models)

11. PARTS LIST

1.	301 MHz. Transmitting RF Board (All Models)	TX-2005
2.	Encoder Board (Alpha 3000F2 Model)	EN-3000F2
	Encoder Board (Alpha 3000F3 Model)	EN-3000F3
	Encoder Board (Alpha 3000D2 Model)	EN-3000D2
	Encoder Board (Alpha 3000D3 Model)	EN-3000D3
3.	301 MHz. Receiving RF Module (All Models)	RX-3000
4.	Decoder Module (All Models)	DE-3000
5.	Upper Rely Board (Alpha 3000F2 Model)	RY-3000F2
	Upper Rely Board (Alpha 3000F3 Model)	RY-3000F3
	Upper Rely Board (Alpha 3000D2 Model)	RY-3000D2
	Upper Rely Board (Alpha 3000D3 Model)	RY-3000D3
6.	Bottom Relay Board (Alpha 3000F2 Model)	RY-3001F2
	Bottom Relay Board (Alpha 3000F3 Model)	RY-3001F3
	Bottom Relay Board (Alpha 3000D2 Model)	RY-3001D2
	Bottom Relay Board (Alpha 3000D3 Model)	RY-3001D3
7.	Transmitter Casing (Alpha 3000F2 & F3 Models)	TC-3000F
	Transmitter Casing (Alpha 3000D2 & D3 Models)	TC-3000D
8.	Receiver Enclosure (All Models)	RC-3000
9.	301 MHz. Receiver Antenna (All Models)	ANT-301
10.	Power Transformer (AC - 110V/220V/380V/415V)	SSB-1726
	(AC - 115V/208V/230V/460V)	SSB-2213
	(AC - 48V/220V/0V/460V)	SSB-2181
11.	1-Step Pushbutton (All Models)	PB-3001
	2-Step Pushbutton (All Models)	PB-3002
	3-Step Pushbutton (All Models)	PB-3003
12.	Emergency Stop Button (All Models)	EMS-3000
13.	Emergency Stop Red Cap (All Models)	RD-3000
14.	Pushbutton Rubber Boot (All Models)	RB-3000
15.	Pushbutton Compass Label (All Models)	DL-3000
16.	Transmitter Power Key + Strap (All Models)	TK-3000
17.	Receiver Panel Key (All Models)	RK-3000
18.	Transmitter Battery Holder (All Models)	BH-3000
19.	Transmitter Battery Cover (All Models)	BC-3000
20.	Cable Gland / Cord Grip (All Models)	CG-3000
21.	Shock Absorber (All Models)	SA-3000
22.	Transmitter Shoulder Strap (All Models)	SS-3000
23.	Protective Vinyl Covering (Alpha 3000F2 & F3 Models)	PC-3000F
	Protective Vinyl Covering (Alpha 3000D2 & D3 Models)	PC-3000D