

Alpha 3000

Industrial Radio Remote Control System

Operation & Parts Manual

Williams USA, LLC

38113 Plymouth Rd., Livonia, Michigan 48150

Phone: 1-734-416-5520, Fax: 1-734-416-1907

Web site: www.williamsrless.com

E-mail: williamsusallc@aol.com

TABLE OF CONTENTS

	Page
1. INTRODUCTION	2
2. SAFETY INSTRUCTION	3
3. TRANSMITTER ILLUSTRATION	
3.1 Alpha 3000F Models External Assembly	4
3.2 Alpha 3000F Models Internal Assembly	5
3.3 Alpha 3000D Models External Assembly	6
3.4 Alpha 3000D Models Internal Assembly	7
4. RECEIVER ILLUSTRATION	
4.1 External Assembly (All Models)	8
4.2 Alpha 3000F Models Internal Assembly	9
4.3 Alpha 3000D Models Internal Assembly	10
5. OUTPUT CONTACT DIAGRAM	
5.1 Alpha 3000F2 Output Contact	11
5.2 Alpha 3000F3 Output Contact	12
5.3 Alpha 3000D2 Output Contact	13
5.4 Alpha 3000D3 Output Contact	14
6. SYSTEM CONFIGURATIONS	
6.1 Jumper Settings	15~17
6.2 Security ID Code Settings	18~19
6.3 Frequency (RF) Channel Settings	19~20
6.4 How to Change the Transmitter Channels.....	20~22
6.5 Frequency (RF) Channel Table	23
6.6 Pushbutton Contact Settings	24
6.7 Voltage Settings	25
6.8 Steps to Change the Frequency Band	26
6.9 Steps to Change the Transmitting Power.....	27
7. RECEIVER INSTALLATION	
7.1 Preparation for Installation	28
7.2 Step-By-Step Installation	28
7.3 System Testing	29
8. TRANSMITTER OPERATION	30~31
9. TROUBLE SHOOTING	32
10. SYSTEM SPECIFICATION	33
11. PARTS LIST	34

1. INTRODUCTION

The Alpha 3000 series are highly durable, reliable, and safe industrial radio remote control system. The versatile features of the Alpha 3000 series permit their usage in many different radio remote control applications that required 2-step or 3-step pushbutton controls. The system can be used to control tower cranes, factory cranes, monorail systems, multiple hoists, trolleys, mining equipment, building construction equipment, automatic control systems, and many others.

The Alpha 3000 radio remote control systems incorporate numerous redundant safety circuits that guaranty maximum security and ensure the system is resistant to outside interference. The major features of the Alpha 3000 series are as follow:

- * The system uses advanced 16+1bit microprocessor control with highly evolved software that has redundant error checking and correcting capabilities to ensure 100% error-free transmission, decoding, and control of all output relays. This highly evolved software includes CRC (cyclical redundancy check codes) and Hamming Codes (error recovery) programming.
- * To insure maximum operating safety, the Alpha 3000 system incorporates numerous important safety features. Some of these built-in safety features include transmitter pushbutton self-diagnosing during initial startup, transmitter low-voltage detection and warning, receiver self-diagnosing, and MAIN deactivation when transmitter is in sleep mode, when strong RF interference is detected, and when the transmitter is out of receiving range.
- * The transmitter encoder and receiver decoder both utilize advanced microprocessor control. The availability of 65,536 sets of unique ID codes + 63 distinct RF channels will ensure that only commands from the matching control transmitter can be carried out without any interference from other radio systems.
- * For added safety, the system also incorporates special type of safety MAIN relay. If the safety MAIN relay becomes defective (fails to open or close during operation), it will signal the central system to shut down immediately to avoid the possibility of any accidents occurring.
- * 63 sets of user-adjustable receiving RF channels via simple dip-switch settings.
- * 100% waterproofed transmitter and receiver enclosures (IP65 rated), including the battery compartment.

Each Alpha 3000 series radio remote control system consists of a water-resistant IP65 handheld transmitter and receiver. The transmitter casing is molded using industrial strength composite materials (Nylon + Fiberglass) which are impervious to dust, water, oil, acids, alkaline, heat, sunlight and as well as being resistant to deformation due to long term use in harsh environments. The industry's best 2-step & 3-step pushbuttons are also constructed from industrial strength composite materials with a minimum of up to one million press cycles. For power savings, the transmitter is designed with an ultra high efficiency power saving circuit that requires only four "AA" size alkaline batteries for more than 200 hours of continuous operation between battery replacements.

2. SAFETY INSTRUCTION

The Alpha 3000 system is relatively simple to use, however, it is very important to observe the proper safety procedures before, during, and after operation. When used properly our Alpha 3000 series remote controls will enhance safety, productivity and efficiency in the workplace.

The following procedures should be strictly followed:

1. Check the transmitter casing and pushbuttons daily. Should any damage that could inhibit the proper operation of the transmitter be found the unit should be immediately removed from service.
2. The transmitter voltage should be checked on a daily basis. If the voltage is low (red status light blinking - refer to page 28), the four "AA" alkaline batteries should be replaced.
3. The red emergency stop button (EMS) should be checked at the beginning of each shift to ensure it is in proper working order and the Stop command is being received.
4. In the event of an emergency, push down the emergency stop button (EMS) immediately to deactivate the transmitter power and the receiver MAIN relay. Then turned the power "off" from the main power source to the crane or equipment.
5. The transmitter power key should be pulled "off" after each use and should never leave the transmitter in the power "on" position when the unit is unattended.
6. Do not use the same RF channel and ID code as any other system in use at the same facility or within distance of 30 meters.
7. Ensure the shoulder strap is worn at all time during operation to avoid accidental damage to the transmitter.
8. Never operate a crane or equipment with two transmitter units at the same time with the same RF channel and ID code.

Caution!

Improper Storage of your Spare Transmitter is a Safety Hazard! During the initial installation of your remote control system the spare (second) transmitter should be tested to confirm that it is functioning properly and then the batteries must be removed and the transmitter stored in a secured place. Failure to follow this safety procedure can result in the inadvertent operation of your crane or hoist by unauthorized personnel resulting in serious injury or death!

3. TRANSMITTER ILLUSTRATION

3.1 Alpha 3000F Models External Assembly

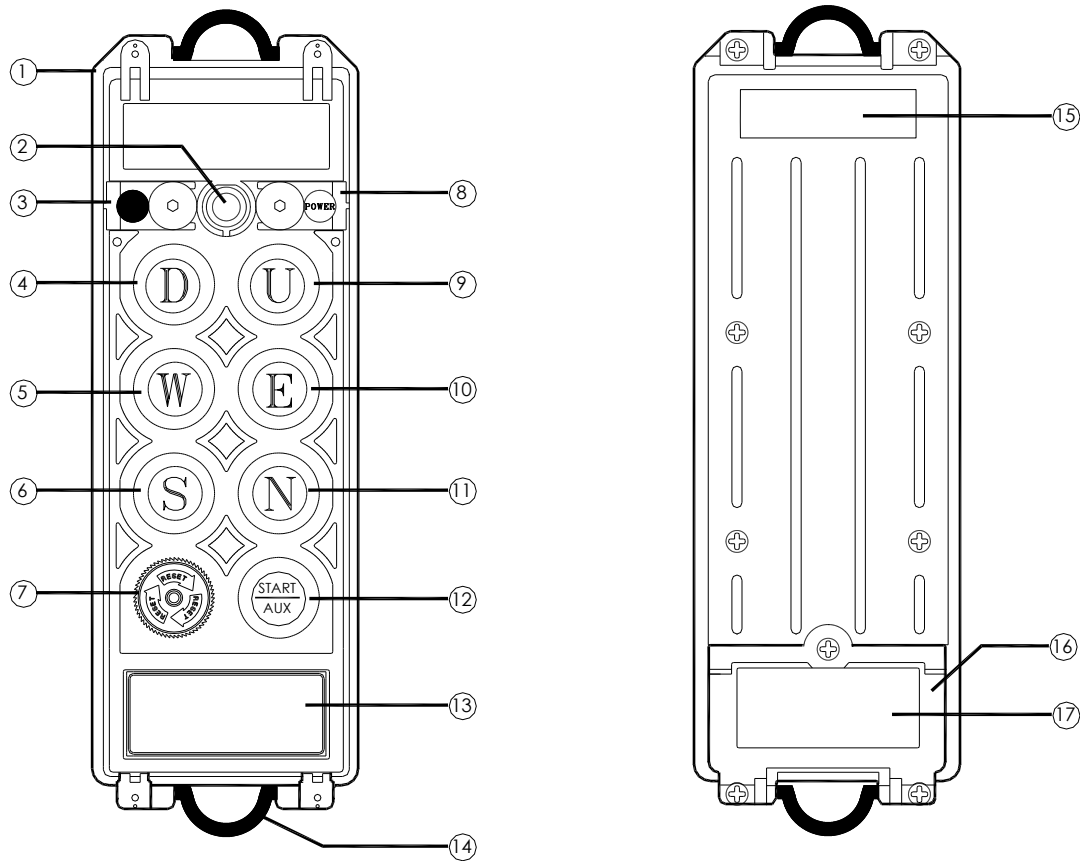

(Transmitter Front View)

(Transmitter Back View)

- | | |
|--------------------------------|-------------------------------|
| 1. Transmitter Unit | 9. Pushbutton #1 (U or ↑) |
| 2. Status LED Display* | 10. Pushbutton #3 (E or →) |
| 3. Spare Power Key | 11. Pushbutton #5 (N or ↗) |
| 4. Pushbutton #2 (D or ↓) | 12. Pushbutton #7 (START/AUX) |
| 5. Pushbutton #4 (W or ←) | 13. Warning Label |
| 6. Pushbutton #6 (S or ↙) | 14. Shoulder Strap Ring |
| 7. Emergency Stop Button (EMS) | 15. System Information |
| 8. Power Key Switch | 16. Battery Cover |
| | 17. FCC/IC Label |

* Please refer to page 25 for transmitter Status LED display information

3.2 Alpha 3000F Models Internal Assembly

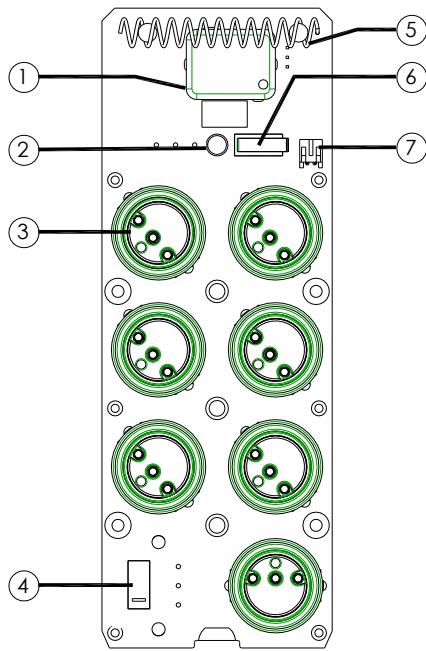

(PCB Front View)

1. RF module
2. Status LED Display
3. 1, 2 or 3-Step Pushbuttons
4. Emergency Stop Button (EMS)
5. Internal Antenna

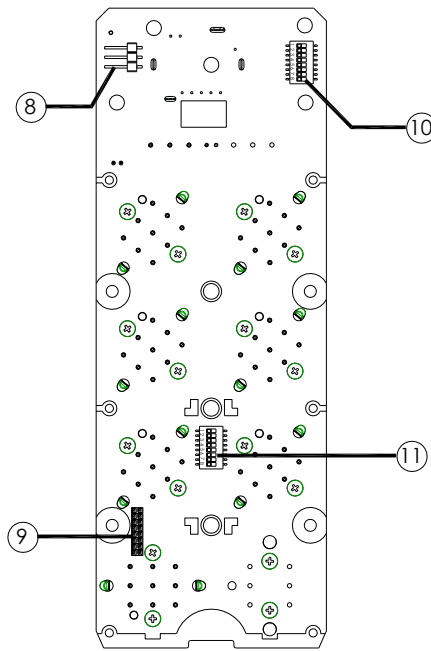

(PCB Back View)

6. Power ON/OFF Micro-Switch
7. Battery Power Connector
8. RF test pin
9. ID Code Soldering Slot (1st ~ 8th digit)
10. Channel Dip-switch
11. ID Code Dip-switch (9th~16th digit)

3.3 Alpha 3000D Models External Assembly

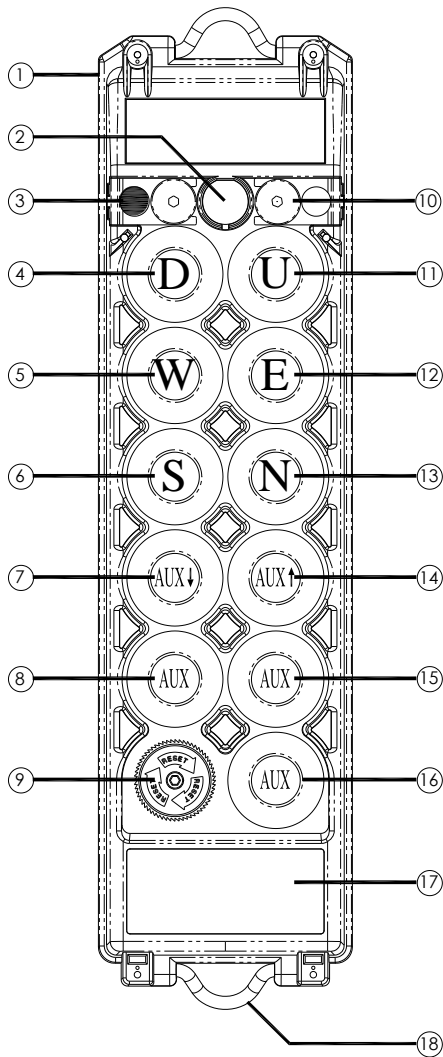

(Transmitter Front View)

1. Transmitter Unit
2. Status LED Display*
3. Spare Power Key
4. Pushbutton #2 (D or ↓)
5. Pushbutton #4 (W or ←)
6. Pushbutton #6 (S or ↙)
7. Pushbutton #8 (AUX or AUX ↓)
8. Pushbutton #10 (AUX or AUX ←)
9. Emergency Stop Button (EMS)
10. Power Key Switch

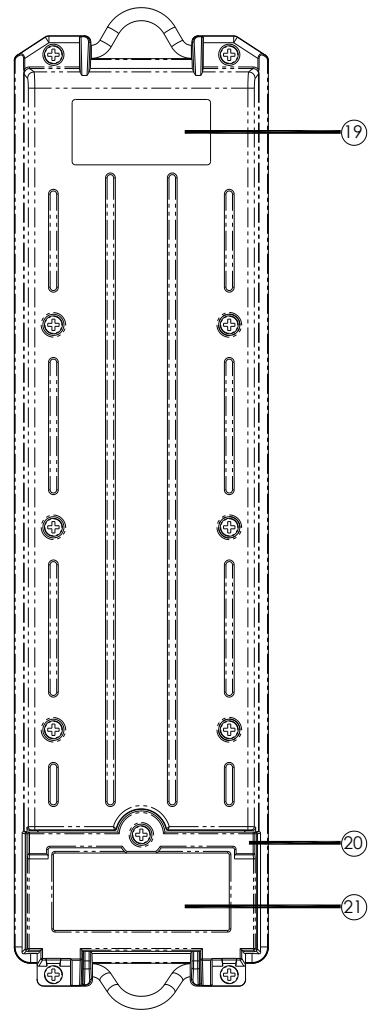

(Transmitter Back View)

11. Pushbutton #1 (U or ↑)
12. Pushbutton #3 (E or →)
13. Pushbutton #5 (N or ↗)
14. Pushbutton #7 (AUX or AUX ↑)
15. Pushbutton #9 (AUX or AUX →)
16. Pushbutton #11 (START/AUX)
17. Warning Label
18. Shoulder Strap Ring
19. System Information
20. Battery Cover
21. FCC/IC Label

* Please refer to page 25 for transmitter Status LED display information

3.4 Alpha 3000D Models Internal Assembly

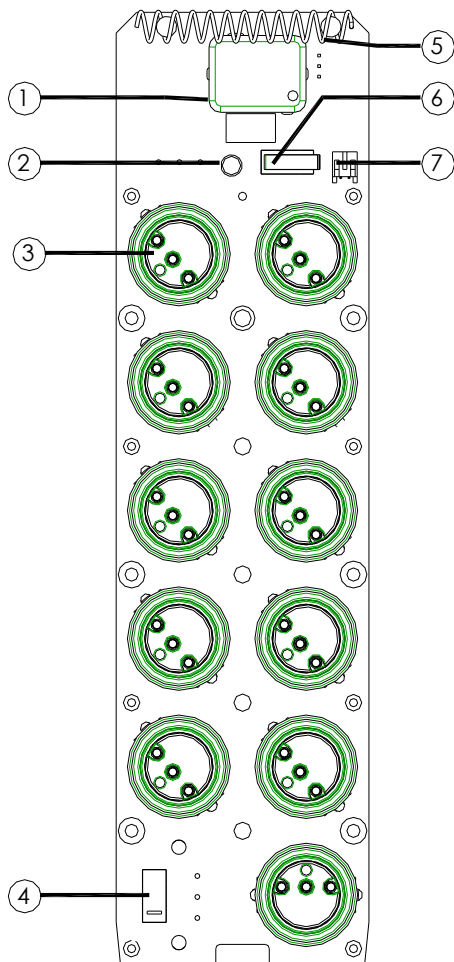

(PCB Front View)

1. RF module
2. Status LED Display
3. 1, 2 or 3-Step Pushbuttons
4. Emergency Stop Button (EMS)
5. Internal Antenna

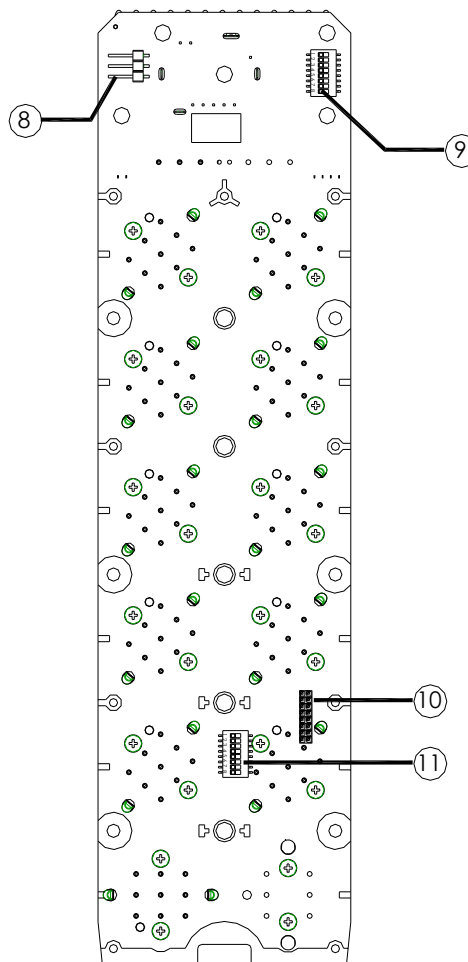

(PCB Back View)

6. Power ON/OFF Micro-Switch
7. Battery Power Connector
8. RF test pin
9. Channel Dip-switch Slot (1st ~ 8th digit)
10. ID Code Soldering
11. ID Code Dip-switch (9th~16th digit)

4. RECEIVER ILLUSTRATION

4.1 External Assembly (All Models)

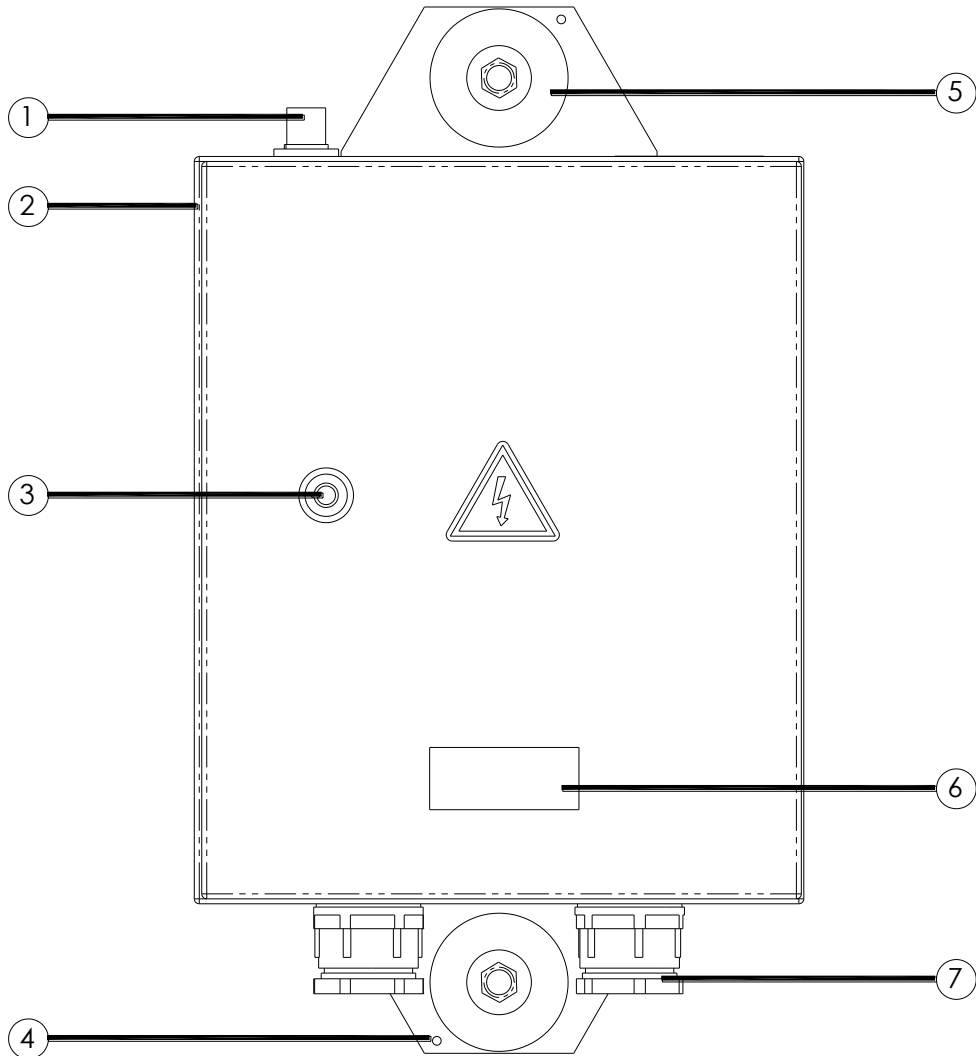

(Alpha 3000 Models Receiver External View)

- | | |
|-----------------------|----------------------------|
| 1. Antenna Seat | 4. External Grounding Hole |
| 2. Receiver Enclosure | 5. Rubber Shock Absorber |
| 3. Key Lock | 6. System Information |
| | 7. Cable Gland/Cord Grip |

4.2 Alpha 3000F Models Internal Assembly

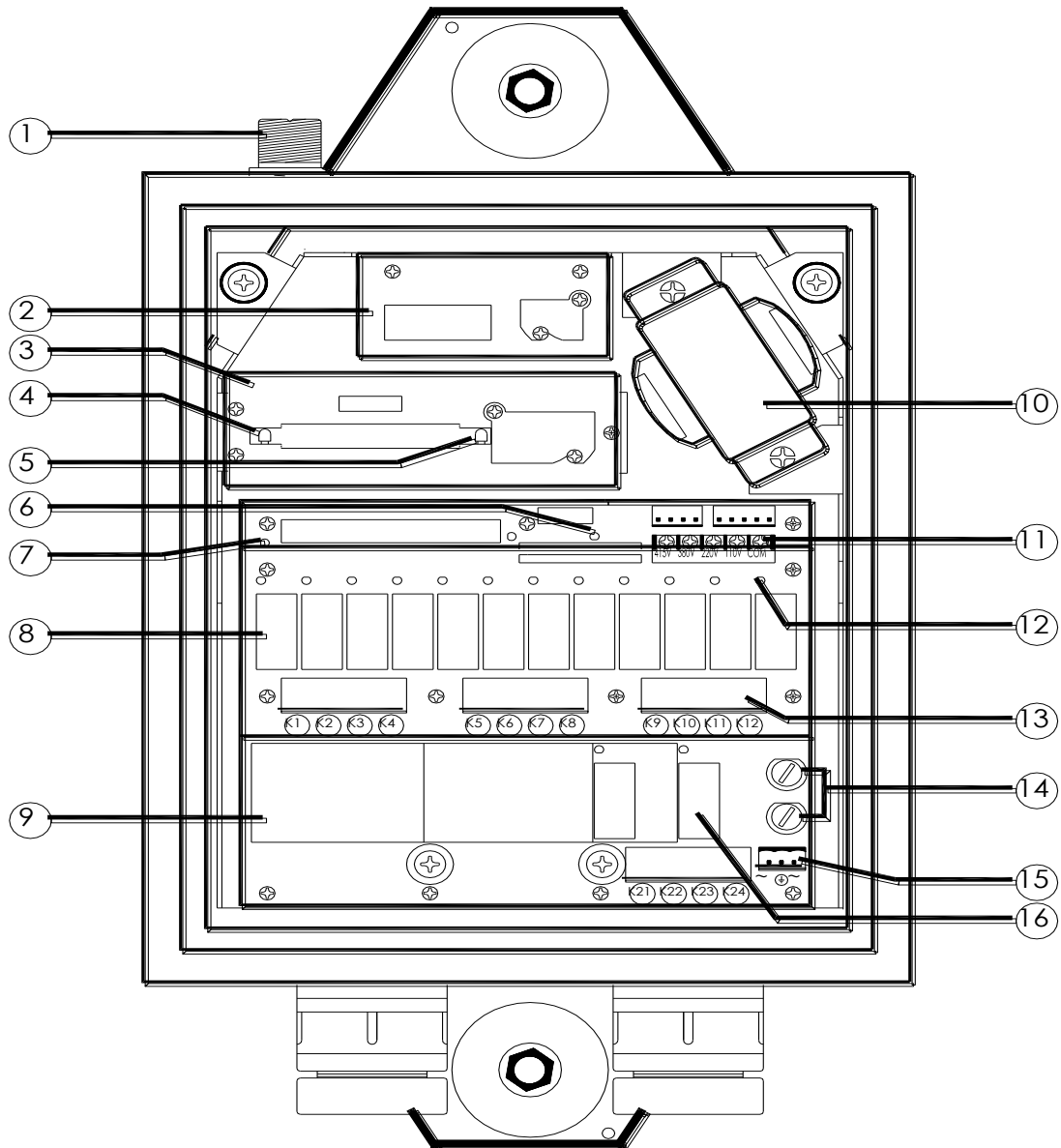

(Alpha 3000F2 & F3 Models Receiver Internal View)

- | | |
|---------------------------------|---------------------------------|
| 1. Antenna Seat | 9. Bottom Relay Board |
| 2. Receiving RF Module | 10. Power Transformer |
| 3. Decoder Module | 11. Input Voltage Selector Seat |
| 4. Decoder Module Power Display | 12. Contact Relay LED Display |
| 5. Receiver Status LED Display* | 13. Terminal Block |
| 6. SQ Status LED Display* | 14. Power Fuses (1.0A) |
| 7. Power (AC) LED Display | 15. AC Power Input |
| 8. Upper Relay Board | 16. MAIN Contact Relay |

* Please refer to page 27 for Receiver and SQ display information

4.3 Alpha 3000D Models Internal Assembly

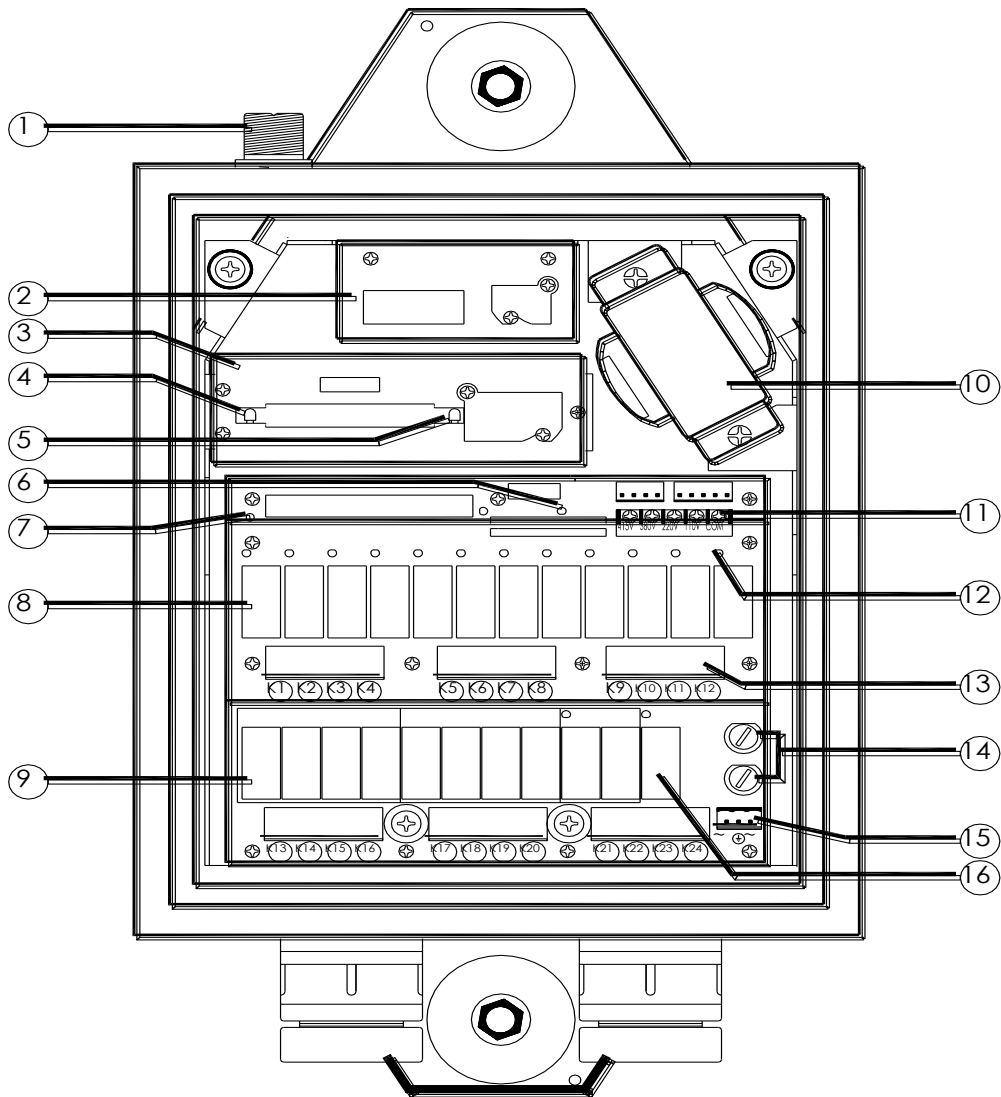

(Alpha 3000D2 & D3 Models Receiver Internal View)

- | | |
|---------------------------------|---------------------------------|
| 1. Antenna Seat | 9. Bottom Relay Board |
| 2. Receiving RF Module | 10. Power Transformer |
| 3. Decoder Module | 11. Input Voltage Selector Seat |
| 4. Decoder Module Power Display | 12. Contact Relay LED Display |
| 5. Receiver Status LED Display* | 13. Terminal Block |
| 6. SQ Status LED Display* | 14. Power Fuses (1.0A) |
| 7. Power (AC) LED Display | 15. AC Power Input |
| 8. Upper Relay Board | 16. MAIN Contact Relay |

* Please refer to page 27 for Receiver and SQ display information

5. OUTPUT CONTACT DIAGRAM

5.1 Alpha 3000F2 Output Contact

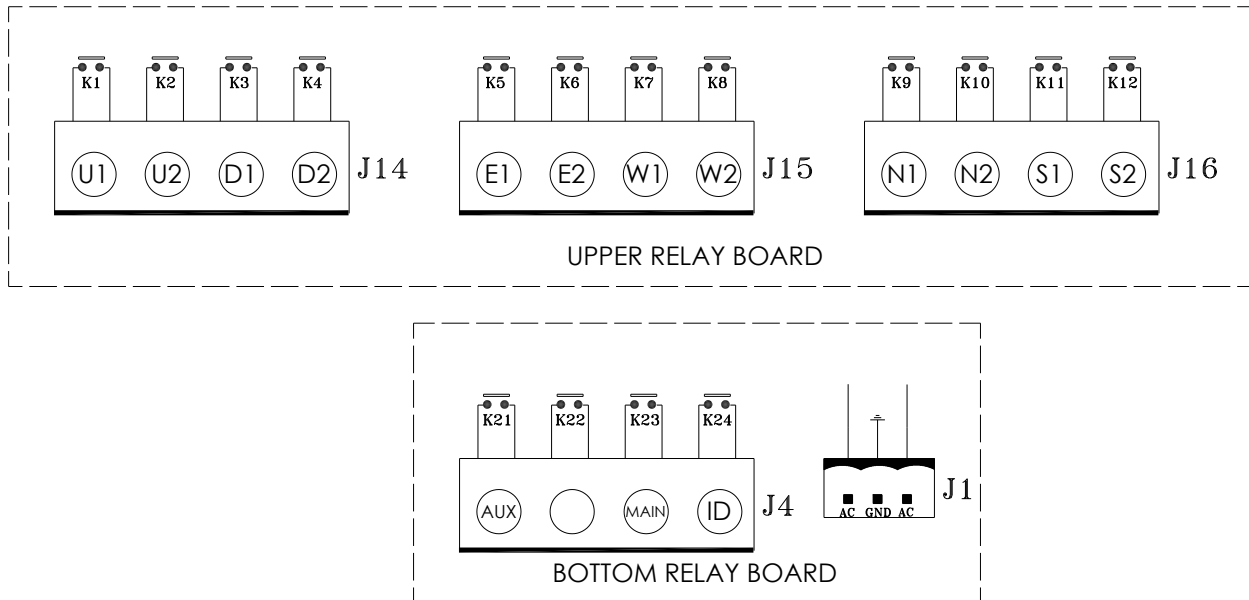

Note A: AUX output contact represents the 7th pushbutton on the transmitter (START/AUX), which can be used for lights, horn, or other types of applications (refer to section 6.6 on page 24).

Note B: The preprinted output contact markings on the relay boards below the terminal blocks are intended for Alpha 3000F3 and Alpha 3000D3 models. If your system is an Alpha 3000F2 or an Alpha 3000D2 model, please ignore the preprinted markings and connect the wires according to the diagram above.

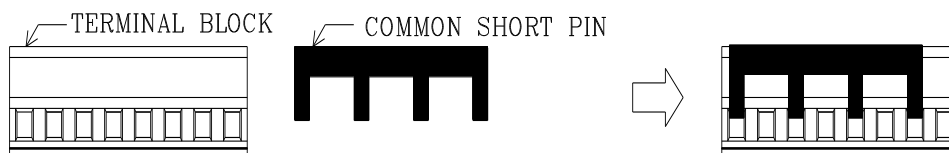

Terminal Block and Common Shorting Pin Assembly

Common shorting pin illustrated above can be used rather than “daisy chaining” wiring for the common.

5.2 Alpha 3000F3 Output Contact

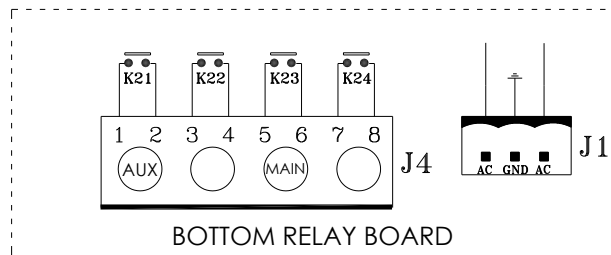
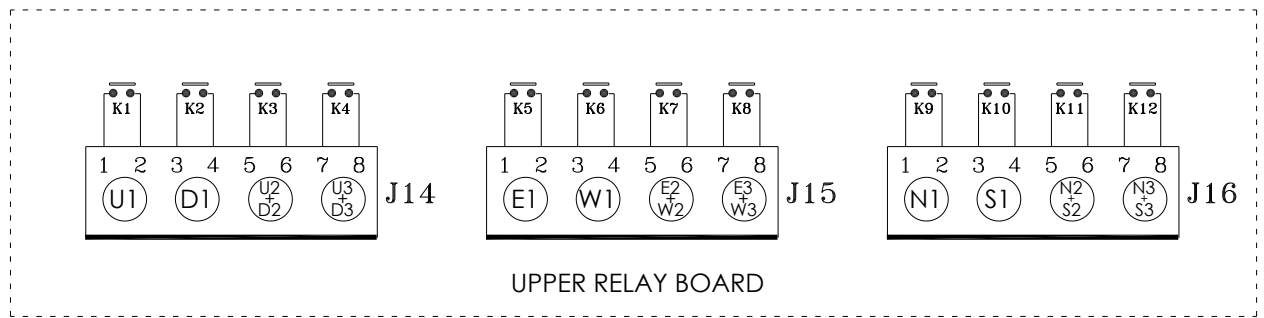

Note: AUX output contact represents the 7th pushbutton on the transmitter (START/AUX), which can be used for lights, horn, or other types of applications (refer to section 6.6 on page 24).

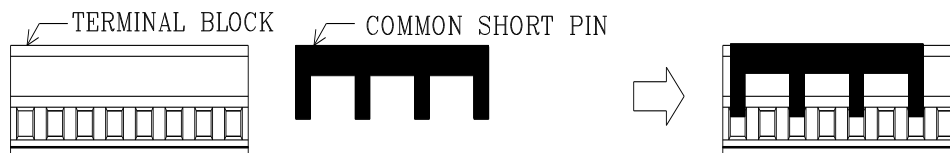

Terminal Block and Common Shorting Pin Assembly

Common shorting pin illustrated above can be used rather than “daisy chaining” wiring for the common.

5.3 Alpha 3000D2 Output Contact

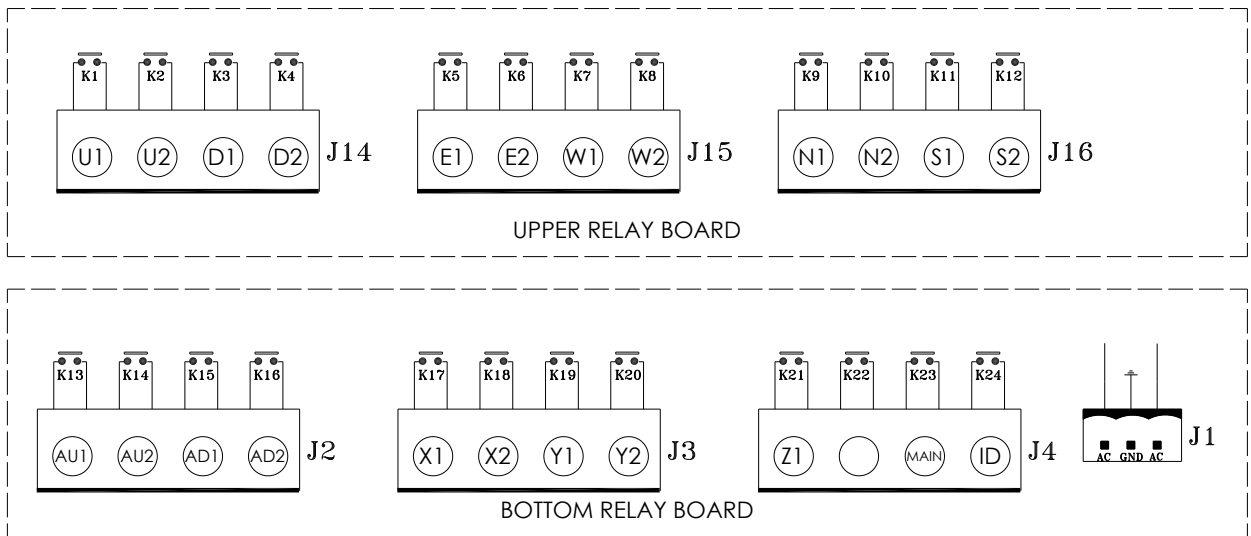

Note A: AU & AD output contacts represent the 7th and 8th pushbuttons on the transmitter (AUX ↑ & AUX ↓), which can be used for the auxiliary hoist motion or other types of applications (refer to section 6.6 on page 24).

Note B: X & Y output contacts represent the 9th and 10th pushbuttons on the transmitter (AUX), which can be used for the auxiliary trolley motion or other types of applications (refer to section 6.6 on page 24). X1 represents 1-speed, X2 represents 2-speed; Y1 represents 1-speed, Y2 represents 2-speed.

Note C: Z1 output contact represents the 11th pushbutton on the transmitter (START/AUX), which can be used for lights, horn, or other types of applications (refer to section 6.6 on page 24).

Note D: The preprinted output contact markings on the relay boards below the terminal blocks are intended for Alpha 3000F3 and Alpha 3000D3 models. If your system is an Alpha 3000F2 or an Alpha 3000D2 model, please ignore the preprinted markings and connect the wires according to the diagram above.

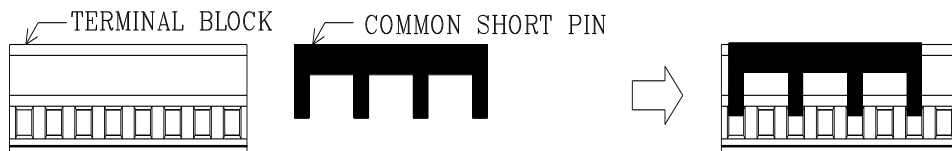

Terminal Block and Common Shorting Pin Assembly

Common shorting pin illustrated above can be used rather than “daisy chaining” wiring for the common.

5.4 Alpha 3000D3 Output Contact

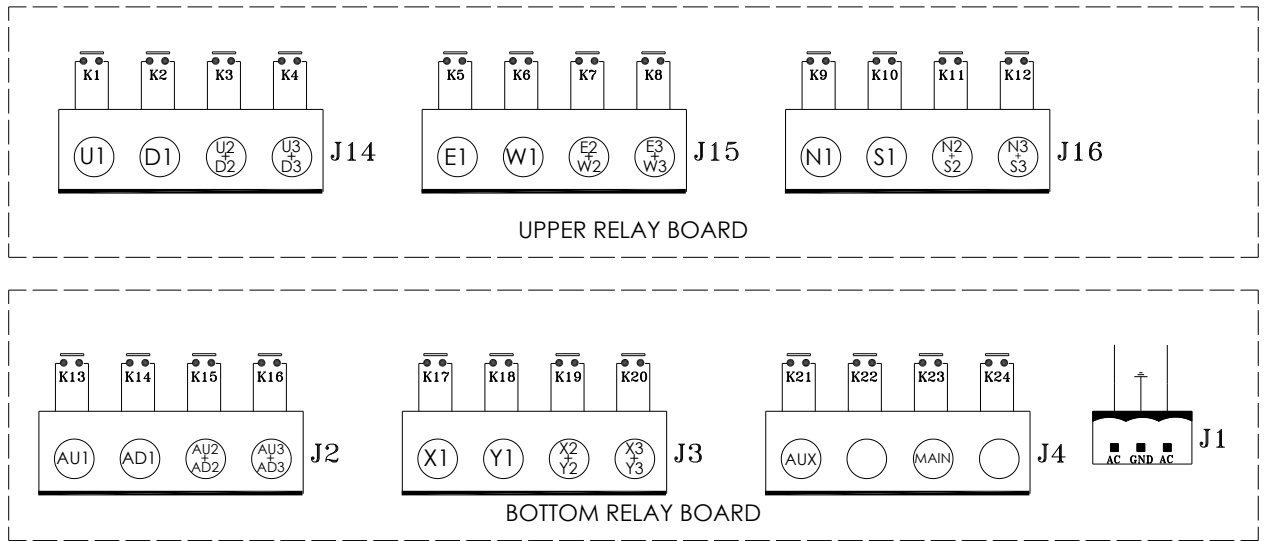

Note A: AU & AD output contacts represent the 7th and 8th pushbuttons on the transmitter (AUX ↑ & AUX ↓), which can be used for the auxiliary hoist motion or other types of applications (refer to section 6.6 on page 24).

Note B: X & Y output contacts represent the 9th and 10th pushbuttons on the transmitter (AUX), which can be used for the auxiliary trolley motion or other types of applications (refer to section 6.6 on page 24). X1 represents 1-speed, X2 represents 2-speed, X3 represents 3-speed; Y1 represents 1-speed, Y2 represents 2-speed, Y3 represents 3-speed.

Note C: AUX output contact represents the 11th pushbutton on the transmitter (START/AUX), which can be used for lights, horn, or other types of applications (refer to section 6.6 on page 24).

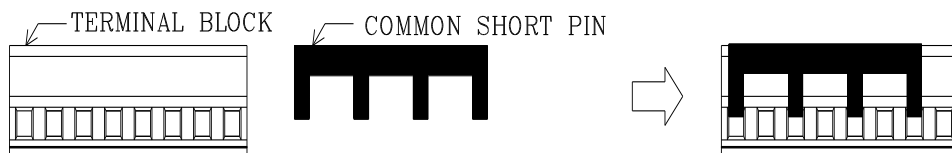

Terminal Block and Common Shorting Pin Assembly

Common shorting pin illustrated above can be used rather than “daisy chaining” wiring for the common.

6. SYSTEM CONFIGURATIONS

6.1 Jumper Settings

There are numerous functions that can be set via jumpers located inside the decoder module. Please see the diagram and chart below on how to set these functions.

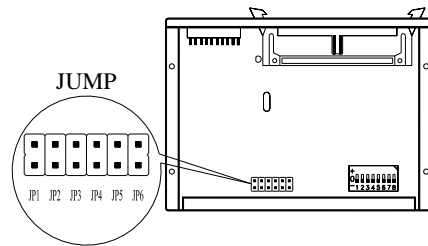

Manufacture Setting for Alpha 3000F2 & D2 Models

JP1	Open	<p>* Insert the transmitter power key will activate the receiver MAIN.</p> <p>* Reset the red EMS button will activate the receiver MAIN (refer to note A).</p>
	Short	<p>* Insert the transmitter power key and press START/AUX pushbutton to activate the receiver MAIN.</p> <p>* After EMS reset, press START/AUX pushbutton to activate the receiver MAIN (refer to Note A).</p>
JP2	Open	After 5 minutes of transmitter non-usage the receiver MAIN relay will be deactivated.
	Short	Receiver MAIN relay stays on constantly until the main power source to the crane or equipment is turned off.
JP3	Open	Both 1 st and 2 nd speed contact relays energized (closed) when either #1 or #2 transmitter pushbutton (U or D) is pressed to the 2 nd speed.
	Short	Only the 2 nd speed contact relay is energized (closed) when either #1 or #2 transmitter pushbutton (U or D) is pressed to the 2 nd speed.
JP4	Open	Both 1 st and 2 nd speed contact relays energized (closed) when either #3 or #4 transmitter pushbutton (E or W) is pressed to the 2 nd speed.
	Short	Only the 2 nd speed contact relay is energized (closed) when either #3 or #4 transmitter pushbutton (E or W) is pressed to the 2 nd speed.
JP5	Open	Both 1 st and 2 nd speed contact relays energized (closed) when either #5 or #6 transmitter pushbutton (N or S) is pressed to the 2 nd speed.
	Short	Only the 2 nd speed contact relay is energized (closed) when either #5 or #6 transmitter pushbutton (N or S) is pressed to the 2 nd speed.

Note A: If JP1 jumper is set to “Short” you must always press START/AUX pushbutton after 3 minutes of transmitter inactivity to reactivate the receiver MAIN relay, that is 3 minutes after the last pushbutton is released. If JP1 jumper is set to “Open”, just press any command pushbutton after 3 minutes of transmitter inactivity to reactivate the receiver MAIN relay. If your system is equipped with Infrared Startup Function, then JP1 jumper must set to “Short”.

Note B: Every time when you change jumper settings you must first turn the receiver power “off” and then turn it back “on” after setting so that they can be stored in memory.

Top Location → "1"
 Bottom Location → "0"

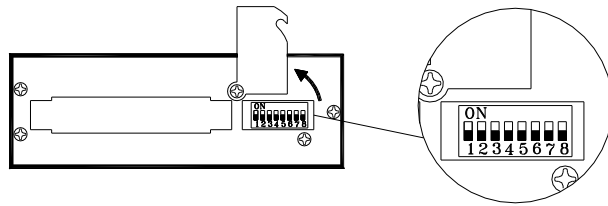

Manufacture Setting for Alpha 3000D2 Model

DIP-8	"0"	Both 1 st and 2 nd speed contact relays energized (closed) when either #7 or #8 transmitter pushbutton (AUX ↑ or AUX ↓) is pressed to the 2 nd speed.
	"1"	Only the 2 nd speed contact relay is energized (closed) when either #7 or #8 transmitter pushbutton (AUX ↑ or AUX ↓) is pressed to the 2 nd speed.

Note: Every time when you change dip-switch settings please make sure to turn the receiver power "off" and then back "on" again so that the newly selected functions can be stored in memory.

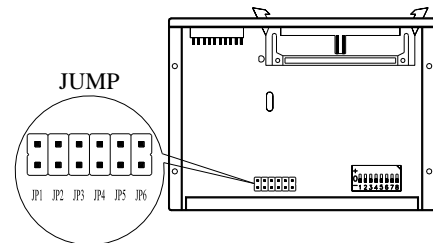

Manufacture Setting for Alpha 3000F3 & D3 Models

JP1	Open	* Insert the transmitter power key will activate the receiver MAIN. * Reset the red EMS button will activate the receiver MAIN (refer to note A).
	Short	* Insert the transmitter power key and press START/AUX pushbutton to activate the receiver MAIN. * After EMS reset, press START/AUX pushbutton to activate the receiver MAIN (refer to Note A).
JP2	Open	After 5 minutes of transmitter non-usage the receiver MAIN relay will be deactivated.
	Short	Receiver MAIN relay stays on constantly until the main power source to the crane or equipment is turned off.
JP3	Open	Pushbutton #1 through #6 interlocked (U/D, E/W, N/S).
	Short	Pushbutton #1 through #6 non-interlocked with single-speed relay contact.
JP4	Open	No acceleration delay from 1 st through 3 rd speed
	Short	Acceleration delay for up to 1 second from 1 st through 3 rd speed

Note A: If JP1 jumper is set to "Short" you must always press START/AUX pushbutton after 3 minutes of transmitter inactivity to reactivate the receiver MAIN relay, that is 3 minutes after the last pushbutton is released. If JP1 jumper is set to "Open", just press any command pushbutton after 3 minutes of transmitter inactivity to reactivate the receiver MAIN relay. If your system is equipped with Infrared Startup Function, then JP1 jumper must set to "Short".

Note B: Every time when you change jumper settings you must first turn the receiver power "off" and then turn it back "on" after setting so that they can be stored in memory.

JP1 (For all models)

JP1 Open	Insert the transmitter power key	Press and hold START/AUX	Receiver MAIN activated	OR	After EMS reset	Press and hold START/AUX	Receiver MAIN activated
JP1 Short	Insert the transmitter power key	Receiver MAIN activated	OR	After EMS reset	Re-insert the transmitter power key	Receiver MAIN activated	Receiver MAIN activated

* POS (power off stop): JP1 Short

JP2 (For all models)

JP2 Open	5 minutes of transmitter non-usage	Receiver MAIN deactivated	Press any pushbuttons	Receiver MAIN reactivated
JP2 Short	Receiver MAIN stays "on" constantly until the main power source to the system is turn "off"			

JP3 (For Alpha 3000F2 & 3000D2 models only)

JP3 Open	Press #1 or #2 (U or D) pushbutton down to the 1 st speed	1 st speed contact relay engaged (closed)	Press #1 or #2 (U or D) pushbutton down to the 2 nd speed	Both 1 st and 2 nd speed contact relays engaged (closed)
JP3 Short	Press #1 or #2 (U or D) pushbutton down to the 1 st speed	1 st speed contact relay engaged (closed)	Press #1 or #2 (U or D) pushbutton down to the 2 nd speed	Only the 2 nd speed contact relay is engaged (closed)

JP3 (For Alpha 3000F3 & 3000D3 models only)

JP3 Open	Pushbutton 1 through 6 interlocked
JP3 Short	Pushbutton 1 through 6 non-interlocked with each pushbutton becomes single-speed contact

JP4 (For Alpha 3000F2 & 3000D2 models only)

JP4 Open	Press #3 or #4 (E or W) pushbutton down to the 1 st speed	1 st speed contact relay engaged (closed)	Press #3 or #4 (E or W) pushbutton down to the 2 nd speed	Both 1 st and 2 nd speed contact relays engaged (closed)
JP4 Short	Press #3 or #4 (E or W) pushbutton down to the 1 st speed	1 st speed contact relay engaged (closed)	Press #3 or #4 (E or W) pushbutton down to the 2 nd speed	Only the 2 nd speed contact relay is engaged (closed)

JP4 (For Alpha 3000F3 & 3000D3 models only)

JP4 Open	No acceleration delay from 1 st through 3 rd speed								
JP4 Short	1 st speed depressed	After 1 second	1 st speed contact relay engaged	2 nd speed depressed	After 1 second	2 nd speed contact relay engaged	3 rd speed depressed	After 1 second	3 rd speed contact relay engaged

JP5 (For Alpha 3000F2 & 3000D2 models only)

JP5 Open	Press #5 or #6 (N or S) pushbutton down to the 1 st speed	1 st speed contact relay engaged (closed)	Press #5 or #6 (N or S) pushbutton down to the 2 nd speed	Both 1 st and 2 nd speed contact relays engaged (closed)
JP4 Short	Press #5 or #6 (N or S) pushbutton down to the 1 st speed	1 st speed contact relay engaged (closed)	Press #5 or #6 (N or S) pushbutton down to the 2 nd speed	Only the 2 nd speed contact relay is engaged (closed)

Dip-8 (For Alpha 3000D2 model only)

DIP-8 "0"	Press #7 or #8 (AUX ↑ or AUX ↓) pushbutton down to the 1 st speed	1 st speed contact relay engaged (closed)	Press #7 or #8 (AUX ↑ or AUX ↓) pushbutton down to the 2 nd speed	Both 1 st and 2 nd speed contact relays engaged (closed)
DIP-8 "1"	Press #7 or #8 (AUX ↑ or AUX ↓) pushbutton down to the 1 st speed	1 st speed contact relay engaged (closed)	Press #7 or #8 (AUX ↑ or AUX ↓) pushbutton down to the 2 nd speed	Only the 2 nd speed contact relay is engaged (closed)

6.2 Security ID Code Settings

Transmitter ID code can be readjusted via an 8-position soldering slot (the first 8 digits of the ID code) and an 8-position dip-switch (the last 8 digits of the ID code). Please refer to page 5 and page 7 for the location of the soldering slot and dip-switch on the encoder board. As for the receiver ID code setting, the soldering slot and the dip-switch are located inside the decoder module; please refer to page 9 & 10 and below illustration.

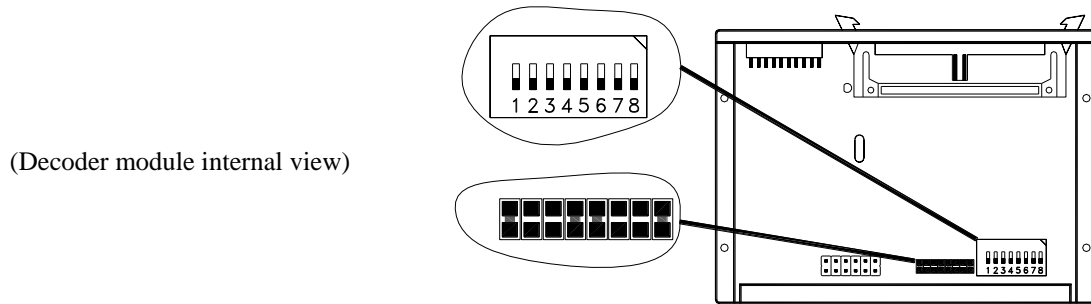

Please note the first 8-digit of the ID code can be changed or altered simply by soldering the two contact points together ("1" value); the position is at "0" value when unsoldered (two points open). The last 8-digit ID code is set via an 8-position dip-switch located next to the 8-position soldering slot.

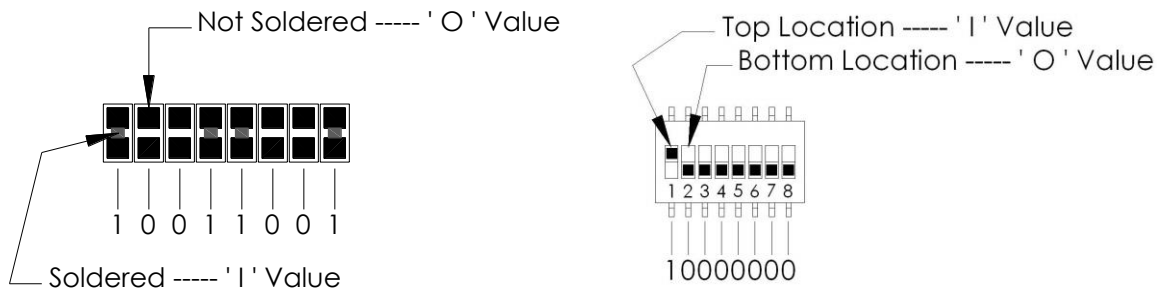

Due to Alpha 3000 series' ID code (or address code) is 16-digit long, the first 8 digits are set via the soldering slot and the remaining last 8 digits are set via the dip-switch (total of 16 digits). For the soldering slot, the "SH8" represents the 1st digit of the ID code and "SH15" represents the 8th digit of the ID code. As for the dip-switch, the "1" represents 9th digit of the ID code and the "8" represents the 16th digit of the ID code (last digit). Next page are some sample illustrations for better understanding on how to set the entire 16-digit ID code via the soldering slot and the dip-switch.

Example 1:

ID code 00000000:10101010

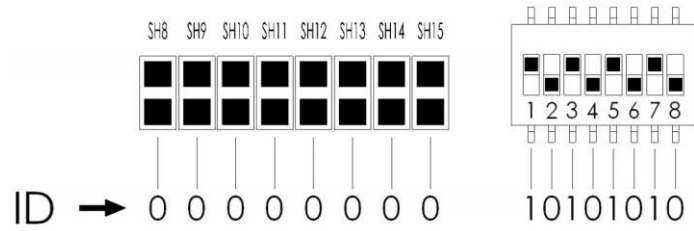

Example 2:

ID code 01011001:00011100

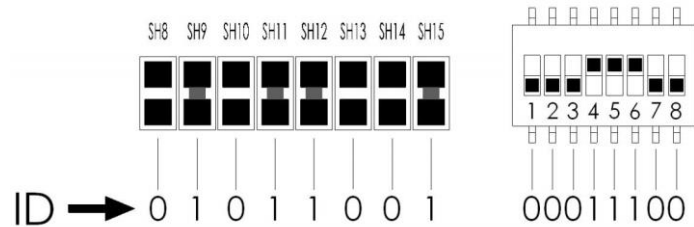

6.3 Frequency (RF) Channel Settings

All Alpha 3000 systems are also equipped with a PLL synthesized receiving RF module with up to 63 user-adjustable RF channels. The RF channel dip-switch is located on the topside of the receiving RF module, covered by a sliding door.

Example: For the below illustrated dip-switch “**000101**” setting, counting from dip-position #1 to #6, the RF channel would be “**205**”, which also represents frequency “**301.205 MHz**”. Please refer to the Frequency (RF) Channel Table or the CHANNEL → DIP label inside the receiver door panel.

Button 2 (Channel Setup): PLL module power on and press button 2 to write in the channel. LED flashes 3 times meaning the new frequency write-in is completed.

Top Slot → “1”

Bottom Slot → “0”

Procedure: 1. Open the sliding door.

2. Set the dip-switch base on the Frequency (RF) Channel Table

3. Power on the module & press button 2.

4. LED flashes 3 times to verify the frequency

5. Close sliding door and screw up.

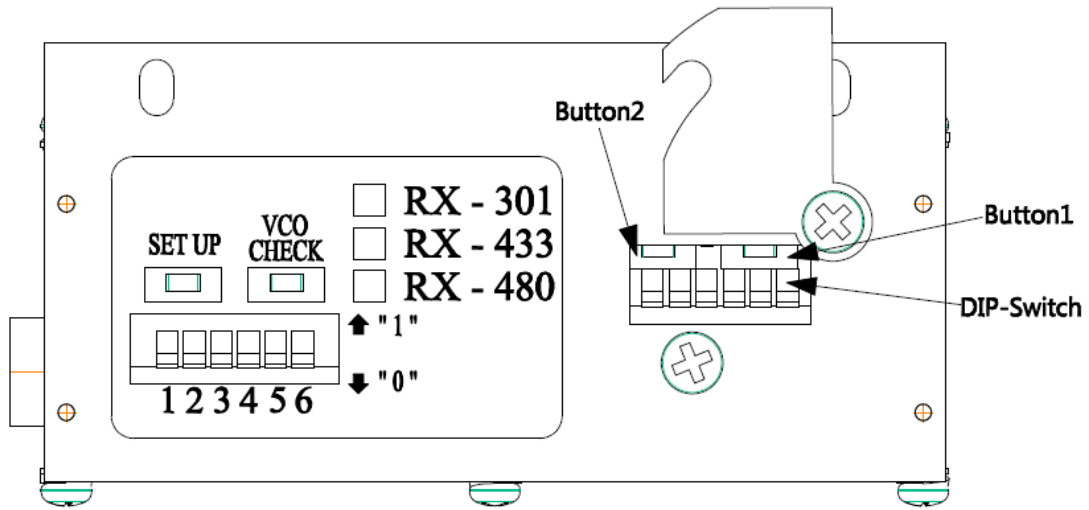

6.4 How to Change The Transmitter Channels

For example: Change from channel 201(301.105MHz) to 202(301.130MHz).

1. Pull out the power key.
2. Unscrew and disassemble the transmitter bottom casing then you will see the encoder board as below

Fig. 1.

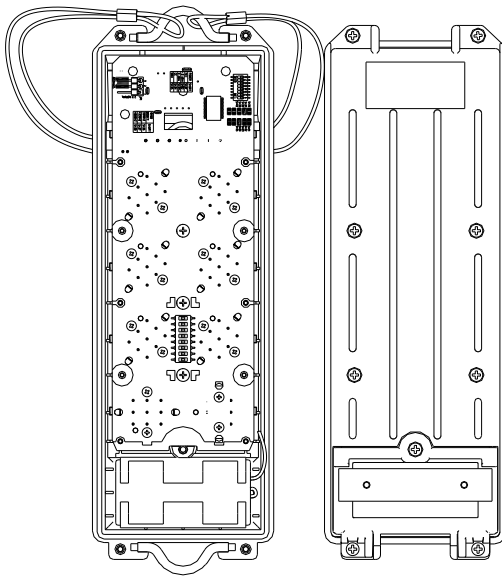

(Fig.1)

3. Take out one of the batteries.
4. Find the DIP3 that is set as channel 201 (00000001) as shown on Fig.2.

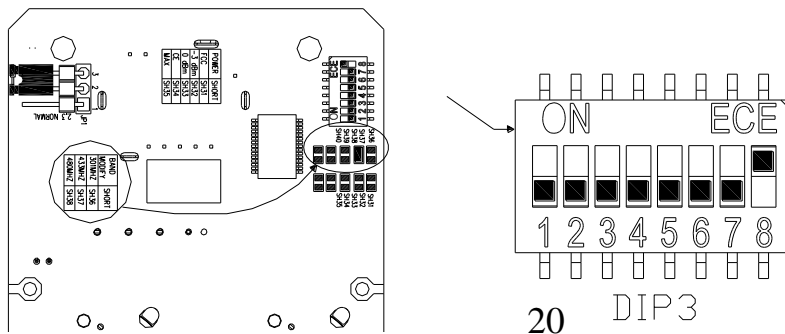

(Fig.2)

5. Change the DIP3 to channel 202 (frequency dip-switch 00000010) as shown on Fig.3.

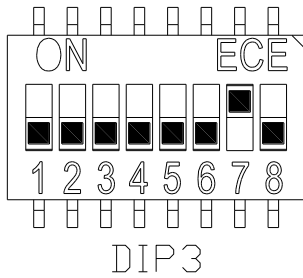

(Fig.3)

6. Change “1” of the DIP3 to “ON” position as shown on Fig.4 to setting status (frequency dip-switch 10000010).

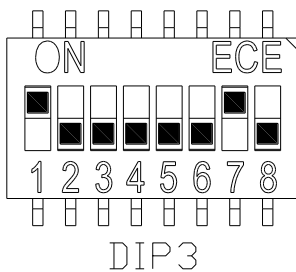

(Fig.4)

7. **Put the battery back into the battery compartment and insert the power key to its original position, then green LED is ON and the change is completed.**
8. After the change, the new channel is 202. Then make sure that the “1” of DIP3 is set to “OFF” position as shown on Fig.3 (frequency ID 00000010), or transmitter will not be activated.
9. Screw and assemble the transmitter bottom casing with transmitter top casing and start the transmitter again to operate.
10. To change the setting to another channel, please refer to the Frequency (RF) Channel Table as below.

※ Functions for Dip-switch DIP3: Top slot “1” for “ON”.

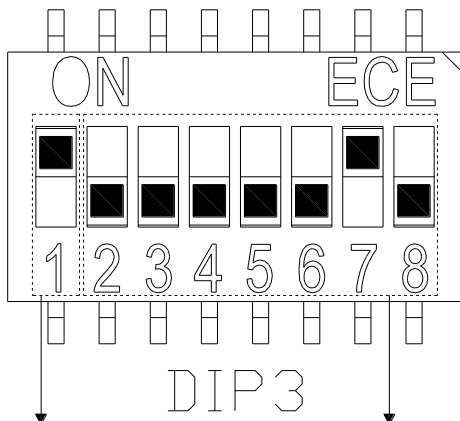

Number 1 is set as the write-in dip-switch. "ON" is the setting status.

Number 2-8 is the binary channel selecting dip-switch. "ON" is "1" and "OFF" is "0".

As shown above, the dip-switch setting is 10000010 for channel 202.

6.5 Frequency (RF) Channel Table

Band 301MHz	Dip-Switch Setting		Channel
	Transmitter	Receiver	
301.1050 MHz	00000001	000001	201
301.1300 MHz	00000010	000010	202
301.1550 MHz	00000011	000011	203
301.1800 MHz	00000100	000100	204
301.2050 MHz	00000101	000101	205
301.2300 MHz	00000110	000110	206
301.2550 MHz	00000111	000111	207
301.2800 MHz	00001000	001000	208
301.3050 MHz	00001001	001001	209
301.3300 MHz	00001010	001010	210
301.3550 MHz	00001011	001011	211
301.3800 MHz	00001100	001100	212
301.4050 MHz	00001101	001101	213
301.4300 MHz	00001110	001110	214
301.4550 MHz	00001111	001111	215
301.4800 MHz	00010000	010000	216
301.5050 MHz	00010001	010001	217
301.5300 MHz	00010010	010010	218
301.5550 MHz	00010011	010011	219
301.5800 MHz	00010100	010100	220
301.6050 MHz	00010101	010101	221
301.6300 MHz	00010110	010110	222
301.6550 MHz	00010111	010111	223
301.6800 MHz	00011000	011000	224
301.7050 MHz	00011001	011001	225
301.7300 MHz	00011010	011010	226
301.7550 MHz	00011011	011011	227
301.7800 MHz	00011100	011100	228
301.8050 MHz	00011101	011101	229
301.8300 MHz	00011110	011110	230
301.8550 MHz	00011111	011111	231
301.8800 MHz	00100000	100000	232

Band 301MHz	Dip-Switch Setting		Channel
	Transmitter	Receiver	
301.9050 MHz	00100001	100001	233
301.9300 MHz	00100010	100010	234
301.9550 MHz	00100011	100011	235
301.9800 MHz	00100100	100100	236
302.0050 MHz	00100101	100101	237
302.0300 MHz	00100110	100110	238
302.0550 MHz	00100111	100111	239
302.0800 MHz	00101000	101000	240
302.1050 MHz	00101001	101001	241
302.1300 MHz	00101010	101010	242
302.1550 MHz	00101011	101011	243
302.1800 MHz	00101100	101100	244
302.2050 MHz	00101101	101101	245
302.2300 MHz	00101110	101110	246
302.2550 MHz	00101111	101111	247
302.2800 MHz	00110000	110000	248
302.3050 MHz	00110001	110001	249
302.3300 MHz	00110010	110010	250
302.3550 MHz	00110011	110011	251
302.3800 MHz	00110100	110100	252
302.4050 MHz	00110101	110101	253
302.4300 MHz	00110110	110110	254
302.4550 MHz	00110111	110111	255
302.4800 MHz	00111000	111000	256
302.5050 MHz	00111001	111001	257
302.5300 MHz	00111010	111010	258
302.5550 MHz	00111011	111011	259
302.5800 MHz	00111100	111100	260
302.6050 MHz	00111101	111101	261
302.6300 MHz	00111110	111110	262
302.6550 MHz	00111111	111111	263

NOTES!!! Be sure to follow the setting steps as shown on page 19~22 for any change of frequency channel.

6.6 Steps to Change the Frequency Band

For example: Change the frequency band from 433MHz to 480MHz.

1. Pull out the power key.
2. Unscrew and disassemble the transmitter bottom casing from the transmitter and you will see the encoder board.
3. Take out the batteries.
4. The below Fig.5 shows the SH number of each frequency band needs to be shorted.

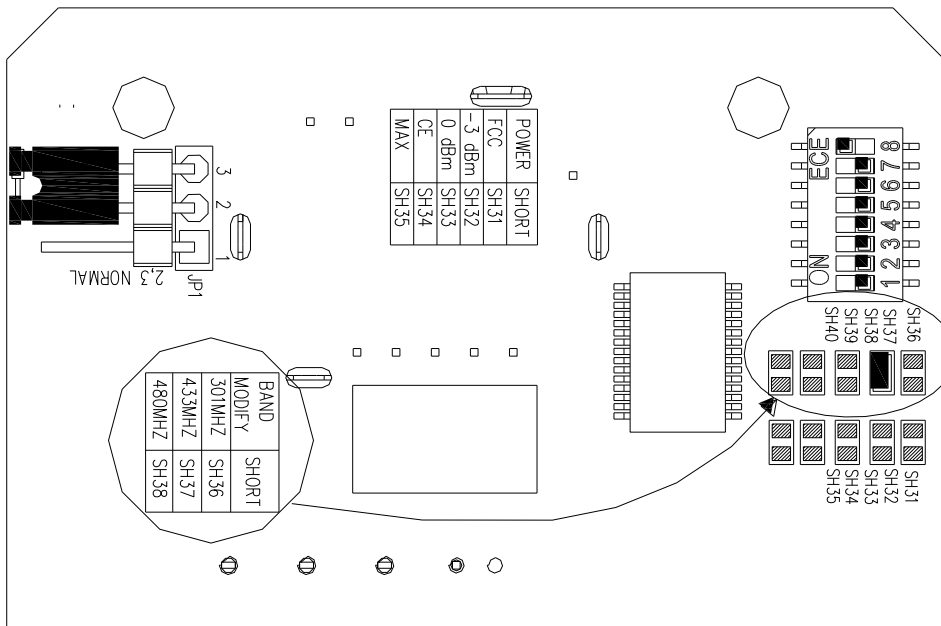

(Fig.5)

5. Unsolder the SH37 to make it open and then short the SH38 for band 480MHz. (see below Fig.6)

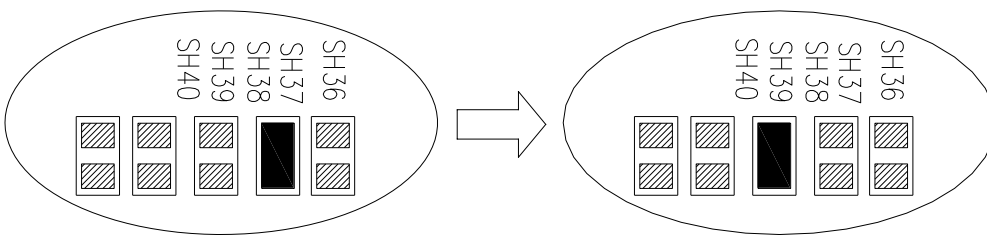

(Fig.6)

6. Assemble the transmitter upper and bottom casings then operate the transmitter by following the regular startup steps.

Remark : Please refer to below Fig.7 for the position of each SH number.

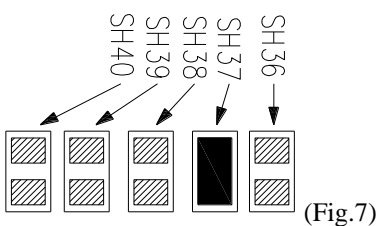

(Fig.7)

6.7 Steps to Change the Transmitting Power

For example: Change the transmitting power from 0dBm to -3dBm.

1. Pull out the power key.
2. Unscrew and disassemble the transmitter bottom casing from the transmitter and you will see the encoder board.
3. Take out the batteries.
4. The below Fig.8 shows the SH number of the transmitting power needs to be shorted.

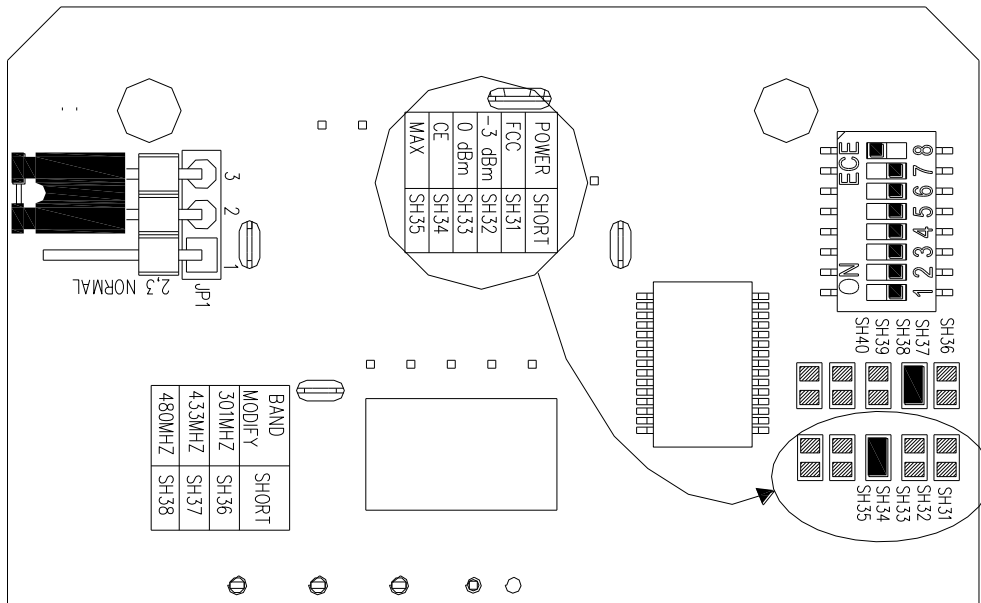

(Fig.8)

5. Unsolder the SH33 to make it open and then short the SH34 for -3dBm. (see below Fig.9)

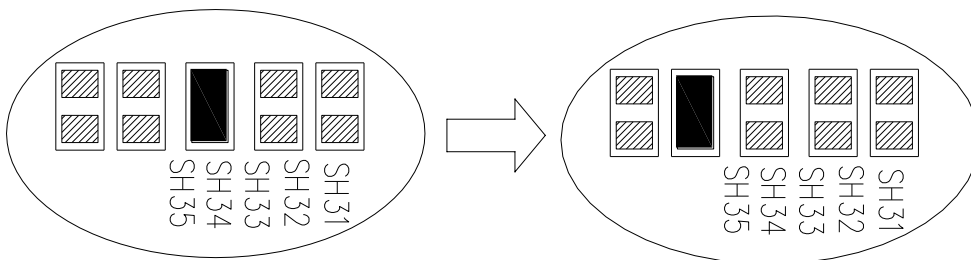

(Fig.9)

6. Assemble the transmitter upper and bottom casings then operate the transmitter by following the regular startup steps.

Remark : Please refer to below Fig.10 for the position of each SH number.

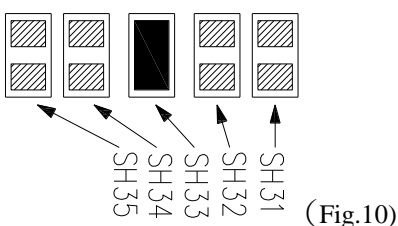

(Fig.10)

6.8 Pushbutton Contact Settings

There are numerous pushbutton functions that can be programmed via an 8-position dip-switch located on the decoder module (refer to the diagram below). By adjusting each dip setting either to the top or bottom location will change the contact form of the intended pushbutton (refer to the chart below). Transmitter pushbuttons are numbered from right-to-left and then from top-to-bottom.

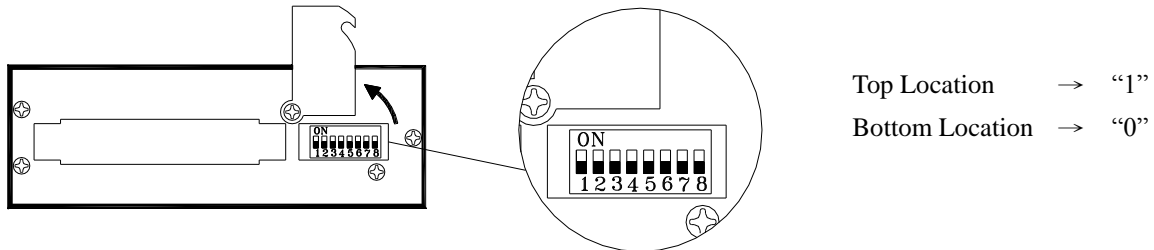

Alpha 3000F Models	<p>DIP1 → “0” → Pushbutton #7 (START/AUX) with momentary relay contact “1” → Pushbutton #7 (START/AUX) with latching relay contact</p>
Alpha 3000D Models	<p>DIP1 → “0” → Pushbutton #11 (START/AUX) with momentary relay contact “1” → Pushbutton #11 (START/AUX) with latching relay contact</p> <p>DIP2 → “0” → Pushbutton #7 & #8 interlocked “1” → Pushbutton #7 & #8 non-interlocked</p> <p>DIP3 → “0” → Pushbutton #7 with momentary relay contact* “1” → Pushbutton #7 with latching relay contact* * DIP2 must set to “1”</p> <p>DIP4 → “0” → Pushbutton #8 with momentary relay contact* “1” → Pushbutton #8 with latching relay contact* * DIP2 must set to “1”</p> <p>DIP5 → “0” → Pushbutton #9 & #10 interlocked “1” → Pushbutton #9 & #10 non-interlocked</p> <p>DIP6 → “0” → Pushbutton #9 with momentary relay contact* “1” → Pushbutton #9 with latching relay contact* * DIP5 must set to “1”</p> <p>DIP7 → “0” → Pushbutton #10 with momentary relay contact* “1” → Pushbutton #10 with latching relay contact* * DIP5 must set to “1”</p> <p>DIP8 → Refer to page 16</p>

6.9 Voltage Settings

There are four different voltage settings available inside the Alpha 3000 receiver located next to the bottom relay board, please select one that corresponds to the main power source of the crane or equipment.

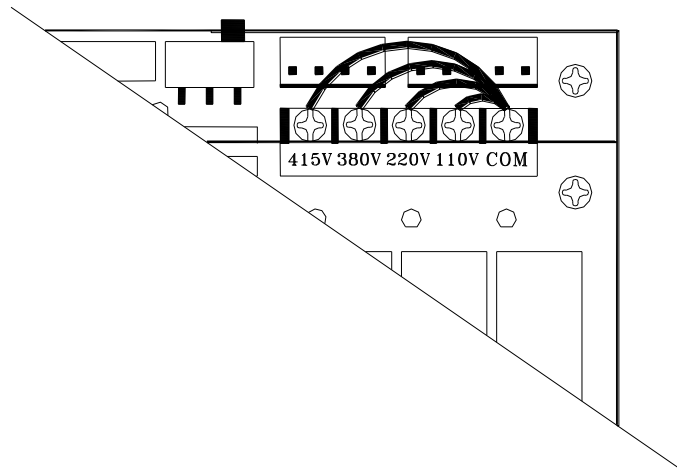

Power Transform Available:

SSB-2181 → 48VAC / 220VAC / 0ACV / 460VAC @ 50/60Hz.

SSB-1726 → 110VAC / 220VAC / 380VAC / 415VAC @ 50/60Hz.

SSB-2213 → 115VAC / 208VAC / 230VAC / 460VAC @ 50/60Hz.

Note A: When different voltage setting is selected, make sure that one end of the wire is connected to the COM position and the other end connected to the voltage position that corresponds to the main power source of the crane or equipment. Also make sure that all screws are tightened prior to turning “on” the main power supply.

Note B: If the receiver system does not respond when the main power source is turn on, then turn the power off and check for any burned or open fuse.

7. RECEIVER INSTALLATION

7.1 Preparation For Installation

1. Required Tools:
 - (1) Flat Head Screwdriver (-)
 - (2) Phillips Head Screwdriver (+)
 - (3) Multi-Meter
 - (4) Open End Wrench
 - (5) Power Drill with 10.5mm ~ 11mm Drill-Bit
2. Check to ensure that your receiver is not set to the same RF channel and ID code as any other systems in operation at the same facility or within distance of 300 meters.
3. Prior to installation, make sure that the crane or equipment itself is working properly.
4. Use a multi-meter to check the voltage source available and ensure that the receiver voltage setting matches your power source.
5. Prior to installation, switch “off” the main power source to the crane or equipment.
6. All pole mains switch or circuit breaker with a contact separation of at least 3 mm in each pole, shall be incorporated in the electrical installation of the building to ensure the possibility of complete disconnection of the apparatus from the mains, if necessary.

7.2 Step-By-Step Installation

1. The location selected should have the antenna visible from all areas where the transmitter is to be used.
2. The location selected should not be exposed to high levels of electrical noise.
3. Ensure the selected location has adequate space to accommodate the receiver enclosure.
4. Make sure the receiver unit is in upright position (vertical).
5. The distance between the antenna and the control panel should be as far apart as possible.
6. Drill two holes on the control panel (10.5mm). Refer to diagrams next page.
7. Tightened the bolt nuts provided.
8. **Ensure AC ground is connected to the power input terminal block otherwise chassis ground should be connected to the chassis ground connection hole on the receiver enclosure (refer to item #4 on page 8).**
9. For system wiring, please refer to the output contact diagram on page 11~14.
10. Ensure all wiring is correct and safely secured and all screws are fastened.

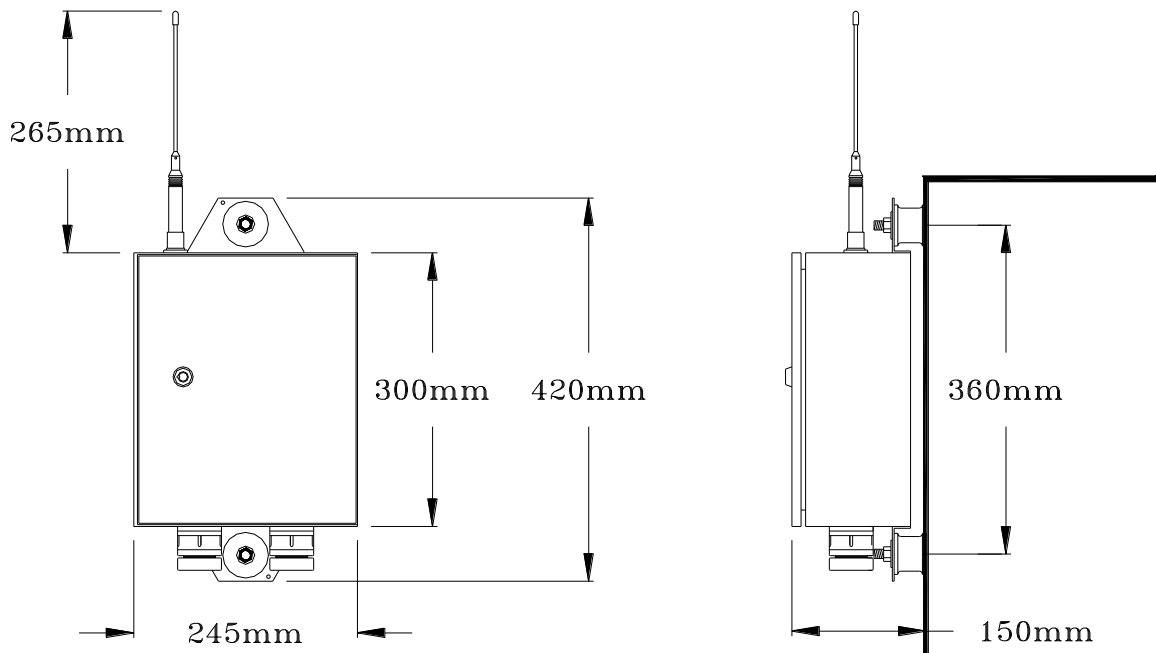

7.3 System Testing

1. Connect the power source to the receiver and test the MAIN relay output (red EMS button) and observe that it properly opens and closes the main line.
2. Test the operation of each function to ensure it corresponds to the transmitter direction labels and/or the pendant it is replacing.
3. Test the limit switches on the crane and verify that they are working properly.
4. If your new remote control is replacing an existing pendant make sure it is completely disconnected to prevent unwanted control commands.
5. If your new remote control is replacing an existing pendant make sure the pushbutton is stored in a safe location where it will not interfere with remote operation.

8. TRANSMITTER OPERATION

- Batteries** _ Make sure the four “AA” alkaline batteries are installed correctly, the labels on the battery holder will tell you which side is “up” and which side is “down”. Use 2,000mA alkaline type batteries for optimum operating time between replacements. If rechargeable batteries are used, for optimum operating time between replacements, select ones rated above 1,600mA.

NOTE!!! To avoid battery leakage, please take out the batteries from the battery compartment if the transmitter is not operated for a long time.

NOTE!!! When screw the battery cover on the transmitter bottom casing, sure to put the battery cover to the position as attached drawing pointed. If not, the batteries might be leaking or even burning.

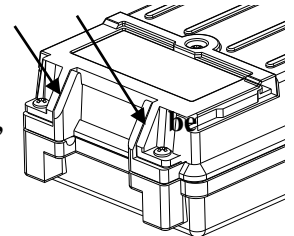

- Startup Procedure** _ Make sure the red EMS button is elevated prior to inserting the transmitter power key, by pulling it upward. Then insert the power key into the key-slot located on the top right-hand side of the transmitter (refer to the diagram at right). The transmitter status LED on the top-center location of the transmitter will display a constant green light for up to 2 seconds when the power key is inserted, followed by series of blinking green lights for up to 3 minutes. Press and hold the START/AUX pushbutton for up to 1.0 second to activate the receiver MAIN relay and transmitter pushbutton functions. If START/AUX pushbutton is not pressed after turning on the transmitter power, both receiver MAIN and all the transmitter pushbutton functions are ineffective.

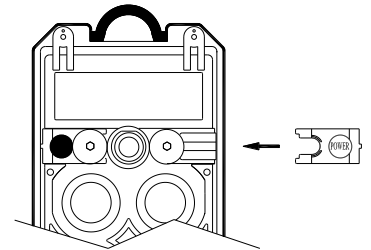

Power off stop (POS): For Mode 0 only. Pull out the transmitter power key, the transmitter will send emergency stop command automatically. Then red status light flashes for 3 times and deactivate the MAIN relay off at the same time.

- Transmitter Status LED Display (refer to item #2 on page 4 & 6)**

TYPE	LED DISPLAY	INDICATION
1	Green “on” → 2.0 seconds	Transmitter power “on”
2	Green “on” → 0.1 second “off” → 2.0 seconds	Transmitter active with signal transmitted
3	Red “on” → 0.1 second “off” → 2.0 seconds	Transmitter low-voltage warning
4	2 fast red blinks followed by 2 seconds “off”	Pushbutton contact jammed or defective
5	Completely “off”	* Transmitter none active or after 3 minutes of inactivity * Emergency stop button activated (button depressed)

- Receiver Main Relay Deactivates in 5 Minutes** _ Your receiver MAIN contact relay is programmed to drop (open) the “Main Line Disconnect Contactor” after 5 minutes of inactivity, that is 5 minutes after the last pushbutton is released. Pressing any pushbutton will close the MAIN relay and start the timing sequence over again. If your crane or hoist is equipped with VFD drive this can sometimes cause an unacceptable delay. In this situation we suggest you

remove the JP2 jumper (refer to JP2 setting on page 15 & 16) then the MAIN relay will remain closed until the “Stop” command is received or the main power source to the crane or equipment is turned off.

5. **EMS & Restarting** _ In case of an emergency, press down the red EMS button will immediately deactivate the transmitter power and receiver MAIN relay. When EMS button is activated (depressed), the green blinking lights on the transmitter status LED will disappear (refer to transmitter status LED display on page 28). To reactivate the transmitter power and the receiver MAIN relay, just pull the red EMS button upward (depending on JP1 jumper setting on page 15 & 16).
6. **Interlocking Pushbuttons** _ For both 3000F & 3000D models the top 3 sets of motions (pushbutton #1 ~ #6) are interlocked to its self so no conflicting commands can take place for safety purpose. For example, pressing the Hoist “UP” and Hoist “DOWN” pushbutton (pushbutton #1 & #2) simultaneously will result in no command being sent.
7. **Initial Start-up Code** _(POS only) Please note that, if JP1 is shorted (without the START function), the receiver unit hence must receive an “**Initial Startup Code**” from the transmitter in order for its MAIN relay to be energized. What this means is that the transmitter can only activate the receiver MAIN relay as long as the operator is within the receiving range. For example, if the operator turned “on” the transmitter in a different area of the facility (beyond 300 feet from the receiver location), then he will not be able to control the crane when he approached within 300 feet. If this happens, the operator would have to resent the initial startup code by reenact the Startup Procedure.
8. **Shutting Off the Transmitter** _ To disconnect the transmitter power and the receiver MAIN relay, just pull out the transmitter power key or press down the red EMS button.
9. **Battery Replacement** _ The transmitter Status LED will display a blinking red light that is “on” 0.1 second and off “2.0 seconds when the transmitter battery power falls below the safety operating voltage, please refer to the table on page 25 for transmitter status LED display information. For battery replacement, just unscrew the battery cover located on the backside of the transmitter handset with a (+) head screwdriver (refer to the diagram below). When changing batteries, do make sure that the batteries are installed correctly. The marking inside the battery holder will tell you which side is positive (+) and which side is negative (-). The battery holder will also tell you which side of the holder is facing up and which side is down.

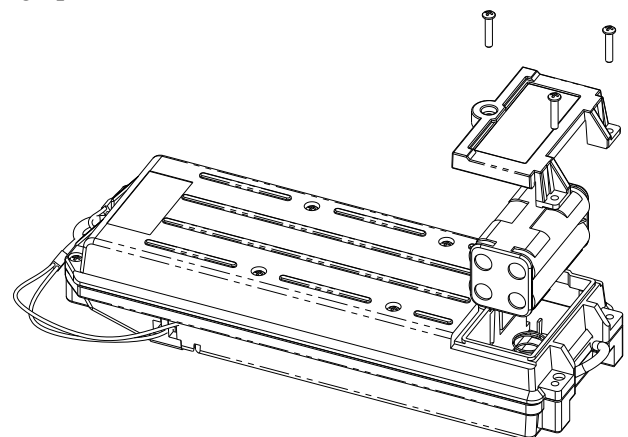

9. TROUBLE

SHOOTING

Should the operator find the equipment not operating normally, please check the chart below for simple trouble shooting tips.

PROBLEM	POSSIBLE REASON	SOLUTION
Transmitter does not communicate to receiver.	Transmitter and the receiver are not on the same RF channel (SQ not lit) or ID code.	Ensure the correct transmitter is in use. The labels on the receiver and the transmitter will identify the RF channel and ID code in use.
Transmitter does not communicate to receiver.	Low or no transmitting power from the transmitter unit.	Turn on the transmitter with EMS button elevated. If the status LED displayed a blinking red light or no lights at all, then turn the power off and replace the four batteries.
No power to the receiver.	Blown fuse or no input power connection.	Ensure power input to the receiver unit is correct. If power indicator (AC) is not lit, please check the receiver for any open fuse.
Outputs do not operate correctly.	Receiver configuration and output wiring is not set properly.	Please refer to section 5 and 6 to ensure receiver is correctly wired and configured for your application.

Receiver Status LED Display (refer to item #5 on page 9 & 10)

TYPE	LED INDICATION	PROBLEM AND SOLUTION
1	3 fast blinks followed by OFF → 2.0 seconds	Defective MAIN contact relay.
2	2 fast blinks followed by OFF → 2.0 seconds	Incorrect ID code setting, please refer to section 6.2.
3	ON → 0.1 second OFF → 2.0 seconds	Decoder on standby.
4	ON → 0.1 second OFF → 0.1 second	Transmitted signal decoded.

SQ Status LED Display (refer to item #6 on page 9 & 10)

TYPE	LED INDICATION	PROBLEM AND SOLUTION
1	ON → 0.1 second OFF → 0.1 second	Transmitted signal received by the receiver.
2	Blinking when transmitter pushbuttons are not depressed	Strong radio interference encountered.

10. **SYSTEM SPECIFICATION**

Transmitter Unit

Frequency Range	:	301 MHz
Transmitting Range	:	100 meters
Hamming Distance	:	≥ 6
Channel Spacing	:	25KHz
Frequency Control	:	Synthesizer (PLL)
Frequency Drift	:	$< 5\text{ppm @ } -25^{\circ}\text{C} \sim +75^{\circ}\text{C}$
Frequency Deviation	:	$< 1\text{ppm @ } 25^{\circ}\text{C}$
Spurious Emission	:	-50dB
Transmitting Power	:	$\sim 1.0\text{mW}$
Emission	:	F1D
Antenna Impedance	:	50 ohms
Enclosure Rating	:	IP-66
Source Voltage	:	DC 6.0V
Current Drain	:	8mA @ 6V
Operating Temperature	:	$-10^{\circ}\text{C} \sim +70^{\circ}\text{C}$
Dimension	:	230mm x 78mm x 47mm (Alpha 3000F Models) 292mm x 78mm x 47mm (Alpha 3000D Models)
Weight (include batteries)	:	600g (Alpha 3000F Models) 730g (Alpha 3000D3 Models)

Receiver Unit

Frequency Range	:	301 MHz
Modulation	:	Narrow Band FM
Frequency Control	:	Synthesizer (PLL)
Frequency Drift	:	$< 5\text{ppm @ } -25^{\circ}\text{C} \sim +75^{\circ}\text{C}$
Frequency Deviation	:	$< 1\text{ppm @ } 25^{\circ}\text{C}$
Sensitivity	:	-122dBm
Antenna Impedance	:	50ohms
Data Decoder Reference	:	Quartz Crystals
Responding Time	:	64~100mS
Enclosure Rating	:	IP-66
Source Voltage	:	AC 48V/110V/220V/380V/415V @ 50/60 Hz.
Power Consumption	:	11VA
Operating Temperature	:	$-10^{\circ}\text{C} \sim +70^{\circ}\text{C}$
Output Contact Rating	:	250V @ 10A
Dimension	:	425mm x 245mm x 130mm (All Models)
Weight (include antenna)	:	8.0kg (All Models)

11. PARTS LIST

1.	Encoder Board (Alpha 3000F2 Model)	EN-3000F2
	Encoder Board (Alpha 3000F3 Model)	EN-3000F3
	Encoder Board (Alpha 3000D2 Model)	EN-3000D2
	Encoder Board (Alpha 3000D3 Model)	EN-3000D3
2.	301 MHz Receiving RF Module (All Models)	RX-3000
3.	Decoder Module (All Models)	DE-3000
4.	Upper Rely Board (Alpha 3000F2 Model)	RY-3000F2
	Upper Rely Board (Alpha 3000F3 Model)	RY-3000F3
	Upper Rely Board (Alpha 3000D2 Model)	RY-3000D2
	Upper Rely Board (Alpha 3000D3 Model)	RY-3000D3
5.	Bottom Relay Board (Alpha 3000F2 Model)	RY-3001F2
	Bottom Relay Board (Alpha 3000F3 Model)	RY-3001F3
	Bottom Relay Board (Alpha 3000D2 Model)	RY-3001D2
	Bottom Relay Board (Alpha 3000D3 Model)	RY-3001D3
6.	Transmitter Casing (Alpha 3000F2 & F3 Models)	TC-3000F
	Transmitter Casing (Alpha 3000D2 & D3 Models)	TC-3000D
7.	Receiver Enclosure (All Models)	RC-3000
8.	301 MHz Receiver Antenna (All Models)	ANT-301
9.	Power Transformer (AC - 110V/220V/380V/415V)	SSB-1726
	(AC - 115V/208V/230V/460V)	SSB-2213
	(AC - 48V/220V/0V/460V)	SSB-2181
10.	1-Step Pushbutton (All Models)	PB-3001
	2-Step Pushbutton (All Models)	PB-3002
	3-Step Pushbutton (All Models)	PB-3003
11.	Emergency Stop Button (All Models)	EMS-3000
12.	Emergency Stop Red Cap (All Models)	RD-3000
13.	Pushbutton Rubber Boot (All Models)	RB-3000
14.	Pushbutton Compass Label (All Models)	DL-3000
15.	Transmitter Power Key + Strap (All Models)	TK-3000
16.	Receiver Panel Key (All Models)	RK-3000
17.	Transmitter Battery Holder (All Models)	BH-3000
18.	Transmitter Battery Cover (All Models)	BC-3000
19.	Cable Gland / Cord Grip (All Models)	CG-3000
20.	Shock Absorber (All Models)	SA-3000
21.	Transmitter Shoulder Strap (All Models)	SS-3000
22.	Protective Vinyl Covering (Alpha 3000F2 & F3 Models)	PC-3000F
	Protective Vinyl Covering (Alpha 3000D2 & D3 Models)	PC-3000D